

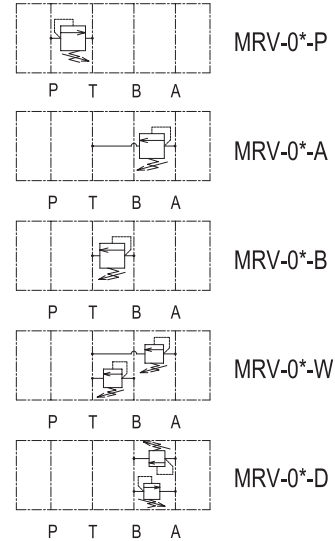

# 積層型溢流閥 Modular Relief Valve



## 型號說明 / HOW TO ORDER :

**MRV — 02 — P — 1 — K**

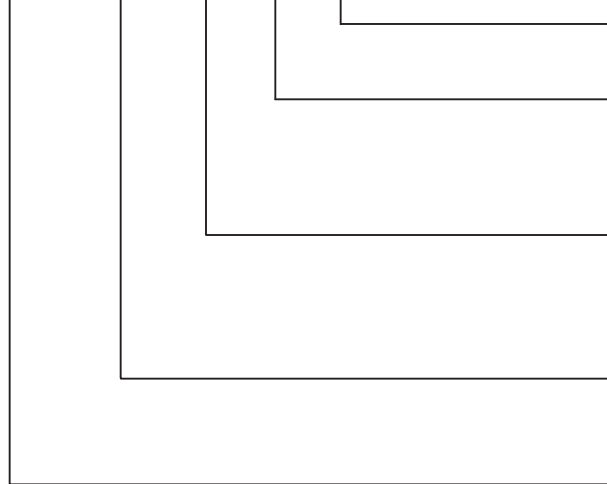

調節型式 : K : 旋鈕 ; 無 : 螺絲調整鈕  
ADJUSTING TYPE: K: with knob none: without

壓力調整範圍 PRESSURE ADJUSTING RANGE  
1: 8-70 kgf/cm<sup>2</sup>  
2: 8-140 kgf/cm<sup>2</sup>  
3: 10-250 kgf/cm<sup>2</sup>

控制孔 CONTROL PORT  
P: P孔 P port W: A及B孔 A&B port  
A: A孔 A port D: T至B和B至A T to B and B to A port  
B: B孔 B port (D: 煞車閥 Brake Valve)

通徑 PORT SIZE  
02 : 1/4" 06 : 3/4"  
03 : 3/8"

積層溢流閥系列 Modular Relief Valve Series

## 規格說明 / SPECIFICATIONS :

型式 MODEL	最高使用壓力 MAX. PRESSURE kgf/cm <sup>2</sup>	壓力調節範圍 PRESSURE ADJ. RANGE kgf/cm <sup>2</sup>	最大流量 MAX. FLOW LPM	重量 WEIGHT (kg)
MRV-02-P/A/B	250	1 : 8-70 2 : 8-140	50	1.7
MRV-02-W/D		3 : 10-250		2.2
MRV-03-P/A/B	250	1 : 8-70 2 : 8-140	100	3.6
MRV-03-W/D		3 : 10-250		4.8
MRV-06-P/A/B	250	1 : 8-70 2 : 8-140 3 : 10-250	180	12.0



# 積層型溢流閥 Modular Relief Valve

## 安裝尺寸 / INSTALLATION DIMENSIONS :

單位 UNIT : mm

### MRV-02-P. A. B

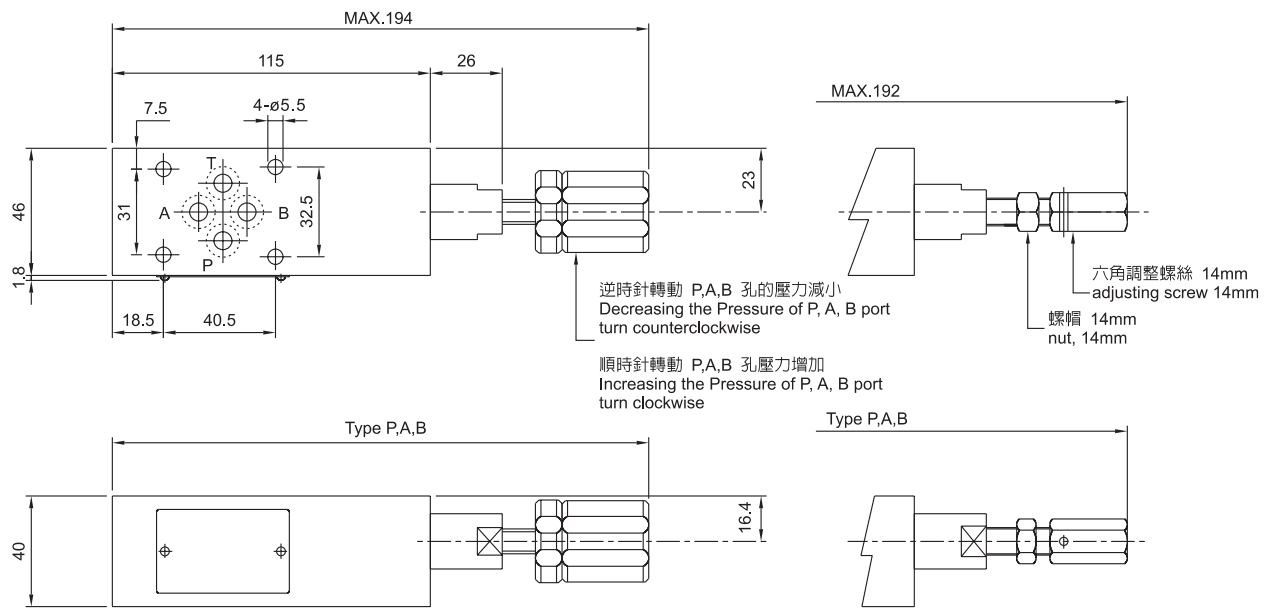

### MRV-02-W. D

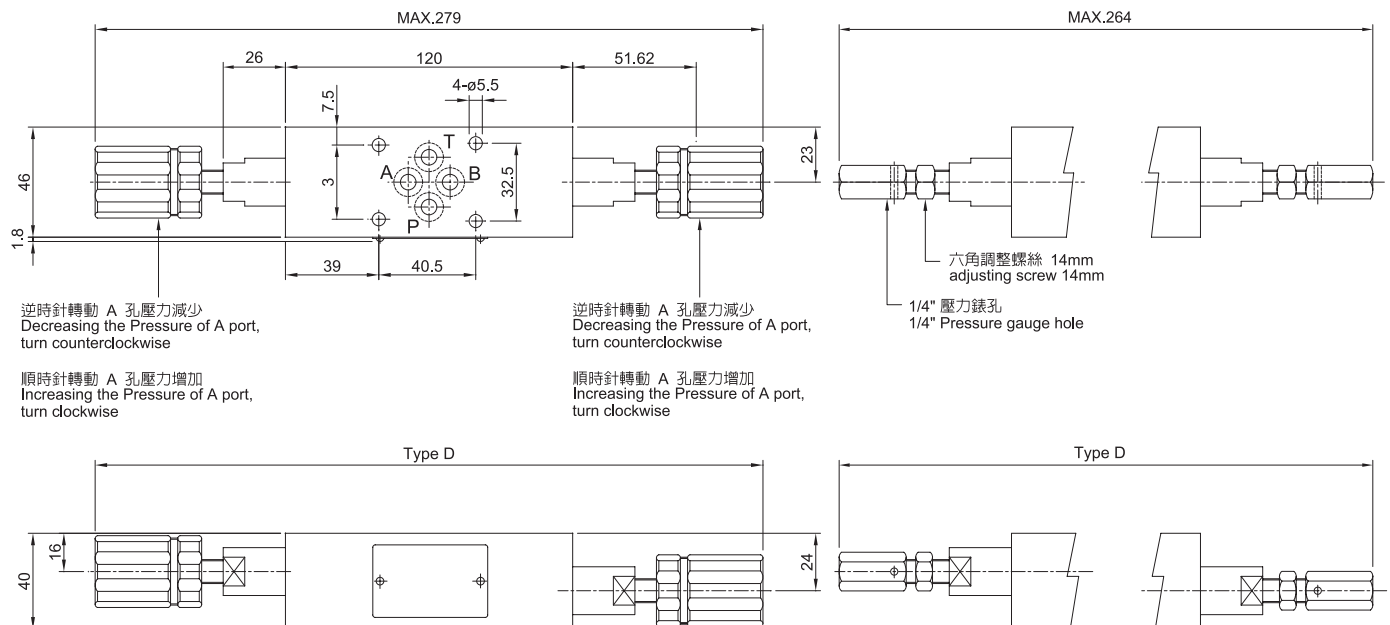

型式 MODEL	A	B	C
MRV-02-W	P51.3	145	MAX.304
MRV-02-D	39	120	MAX.279



# 積層型溢流閥 Modular Relief Valve

## 安裝尺寸 / INSTALLATION DIMENSIONS :

單位 UNIT : mm

### MRV-03-P. A. B

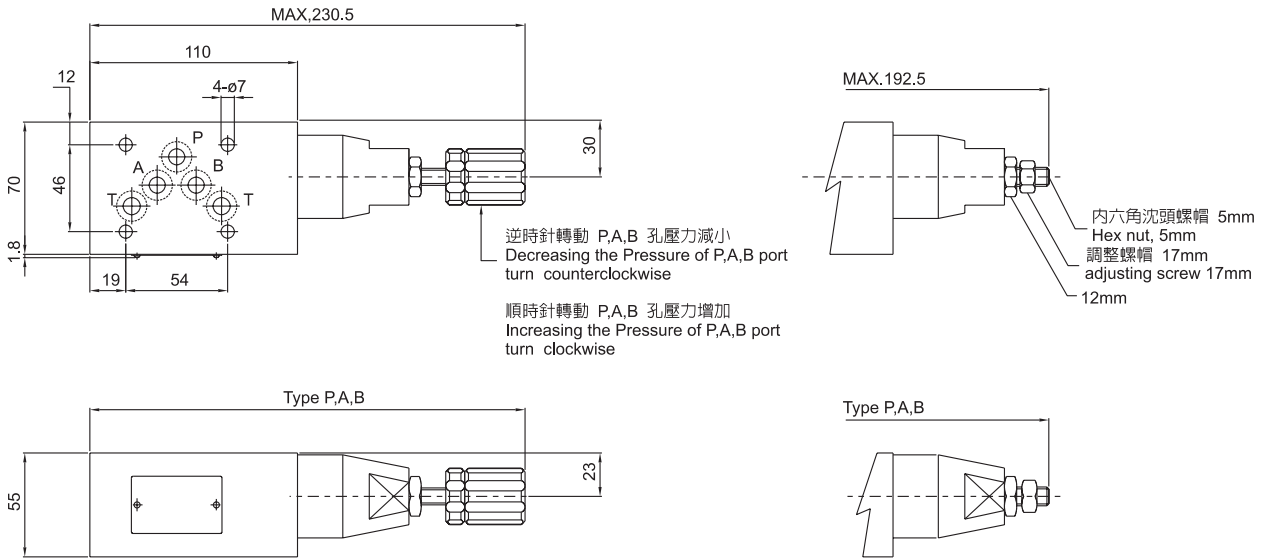

### MRV-03-W. D

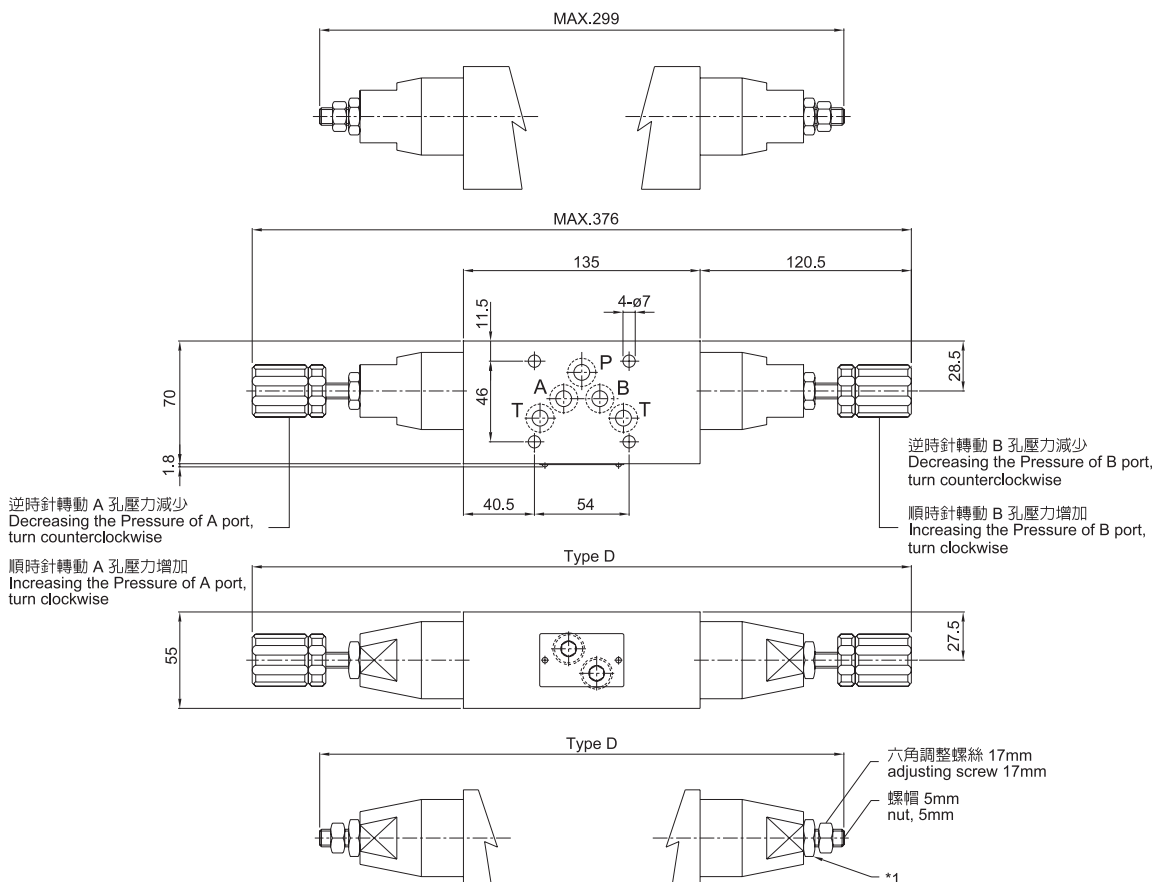



# 積層型溢流閥 Modular Relief Valve

## 安裝尺寸 / INSTALLATION DIMENSIONS :

單位 UNIT : mm

### MRV-06-P. A. B

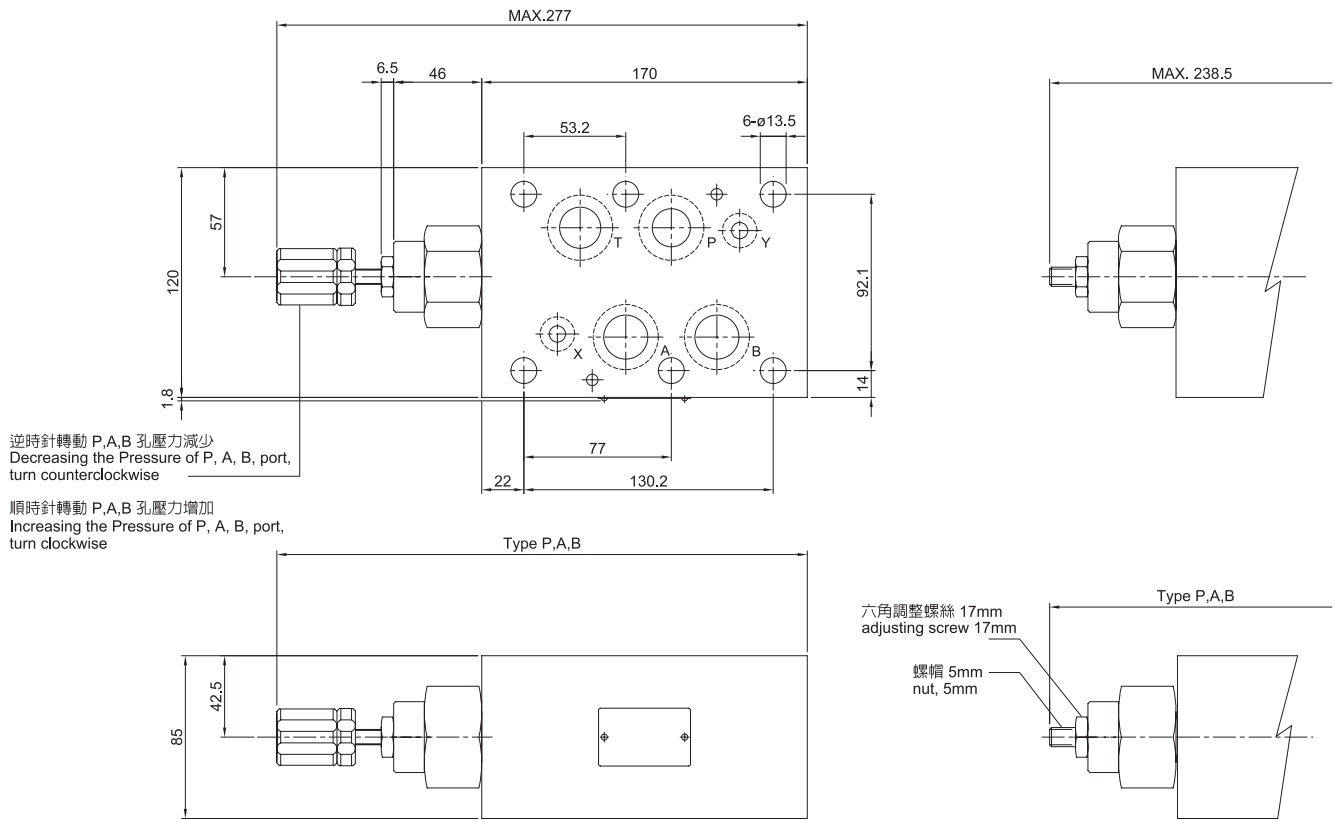



# 積層型減壓閥

## Modular Reducing Valve

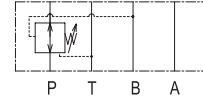
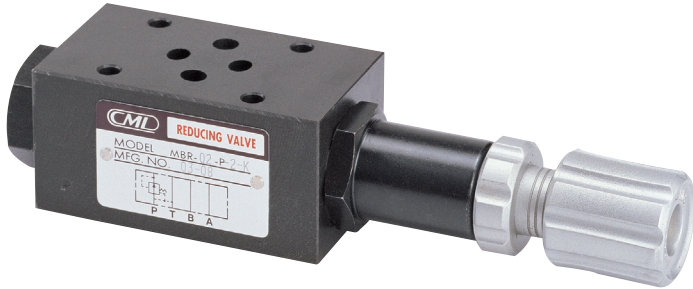

MBR-0\*-B

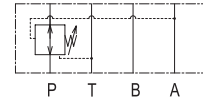

MBR-0\*-A

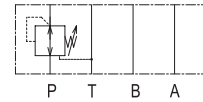

MBR-0\*-P

### 型號說明 / HOW TO ORDER :

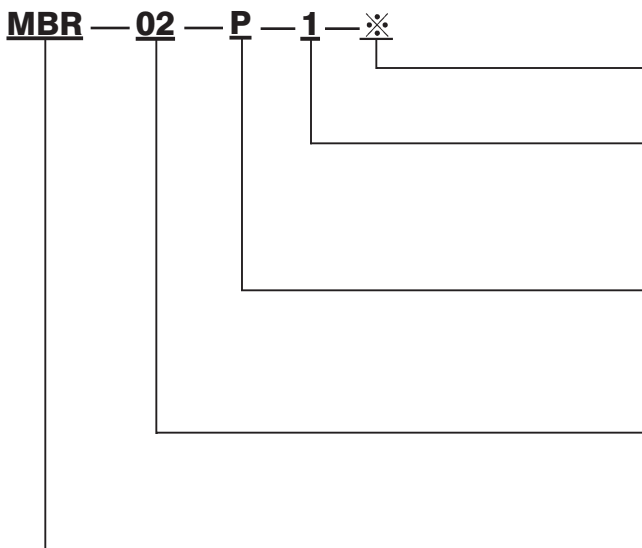

調節型式 : K : 旋鈕 : 無 : 螺絲調整鈕  
 ADJUSTING TYPE: K: with knob none: without

壓力調節範圍 PRESSURE ADJUSTING RANGE  
 1: 3-35 kgf/cm<sup>2</sup> 1S: 1.5-35 kgf/cm<sup>2</sup>  
 2: 8-70 kgf/cm<sup>2</sup> 1S: 8-140 kgf/cm<sup>2</sup>  
 3: 10-250 kgf/cm<sup>2</sup> 1S: 8-250 kgf/cm<sup>2</sup>

控制孔 CONTROL PORT  
 P: P孔 P port  
 A: A孔 A port  
 B: B孔 B port

通徑 PORT SIZE  
 02 : 1/4" 06 : 3/4"  
 03 : 3/8"

積層型減壓閥 Modular Reducing Valve Series

### 規格說明 / SPECIFICATIONS :

型式 MODEL	最高使用壓力 MAX. PRESSURE kgf/cm <sup>2</sup>	壓力調節範圍 PRESSURE ADJ. RANGE kgf/cm <sup>2</sup>	最大流量 MAX. FLOW LPM	重量 WEIGHT (kg)
MBR-02-P/A/B	250	1 : 3-35 2 : 8-70 3 : 10-250 1S : 1.5-35, 2S : 8-140, 3S : 8-250	50	1.4
MBR-03-P/A/B	250	1 : 3-35 2 : 8-70 3 : 10-250 1S : 1.5-35, 2S : 8-140, 3S : 8-250	100	3.7
MBR-06-P/A/B	250	1 : 3-35 2 : 8-70 3 : 10-250 1S : 1.5-35, 2S : 8-140, 3S : 8-250	180	12.3



# 積層型減壓閥

# Modular Reducing Valve

## 安裝尺寸 / INSTALLATION DIMENSIONS :

單位 UNIT : mm

### ■ MBR-02-P. A. B

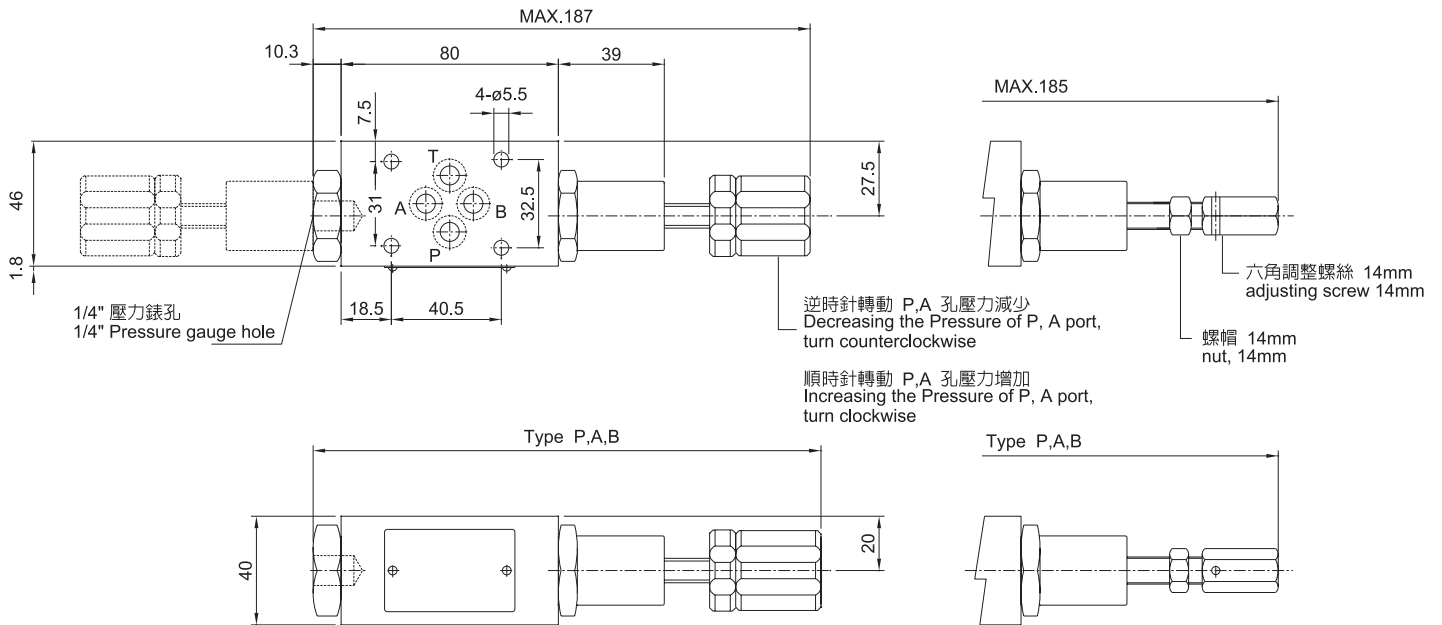

### ■ MBR-03-P. A. B

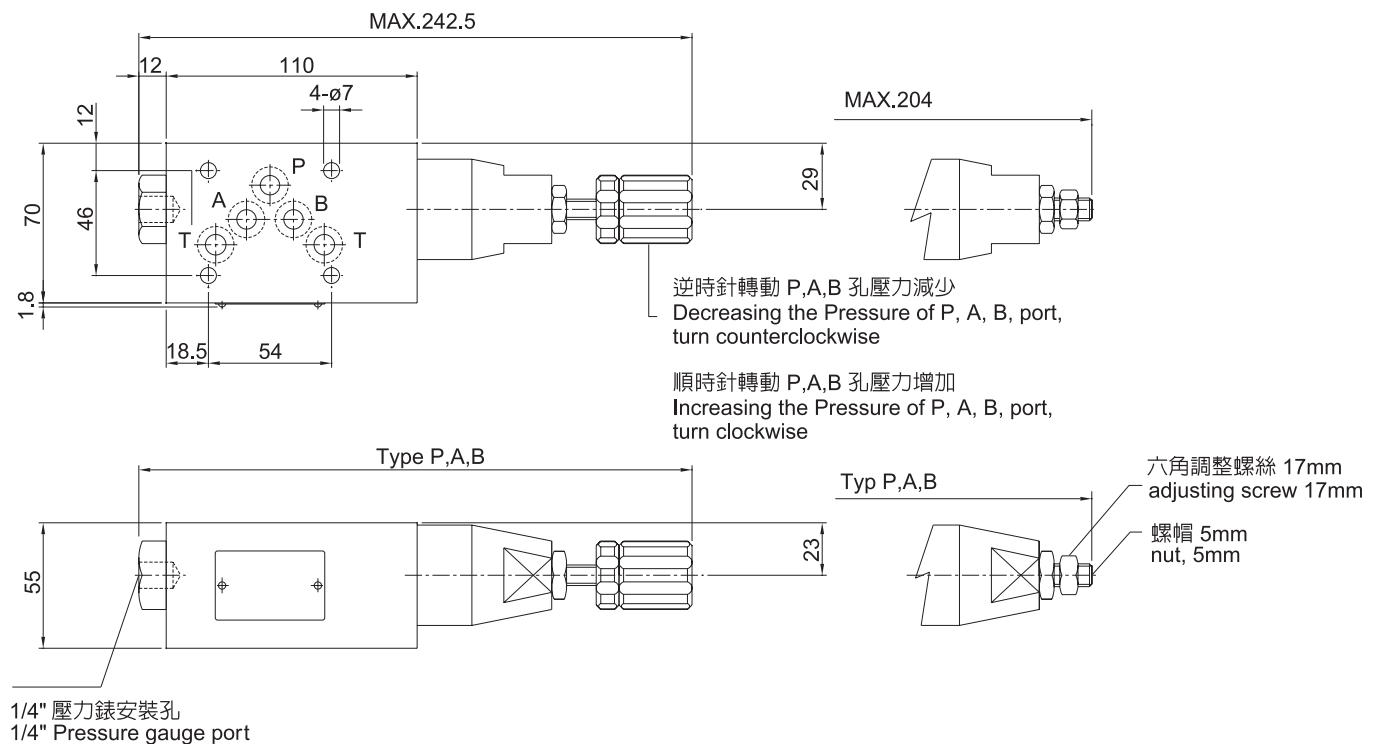





# 積層型二段減壓閥

# Modular Tow Section Reducing Valves

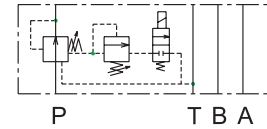
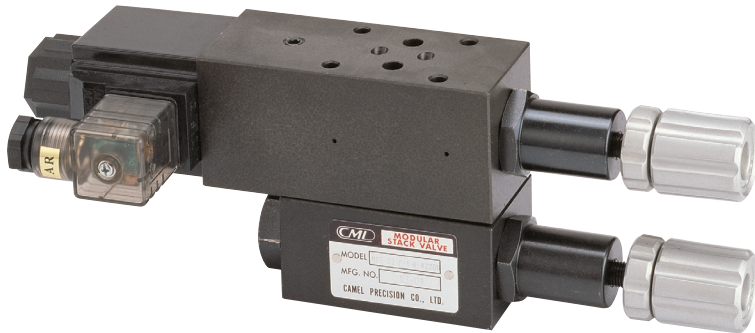

## 型號說明/HOW TO ORDER :

**MGS — 02 — P — A110N**

線圈電壓  
COIL VOLTAGE  
A110N/A220N  
DC12N/DC24N

控制孔  
CONTROL PORT  
**P:** P PORT

通徑  
PORT SIZE  
**02:** 1/4"

積層型二段減壓閥系列  
Modular Tow Section Reducing Valves Series

## 規格說明/SPECIFICATIONS :

型式 MODEL	壓力 RATED PRESSURE	流量 RATED FLOW	壓力調節範圍 PRESSURE ADJ RANGE
MGS-02-P	140 kgf/cm <sup>2</sup>	40 l/min	2~70 kgf/cm <sup>2</sup>

## 安裝尺寸/INSTALLATION DIMENSIONS :

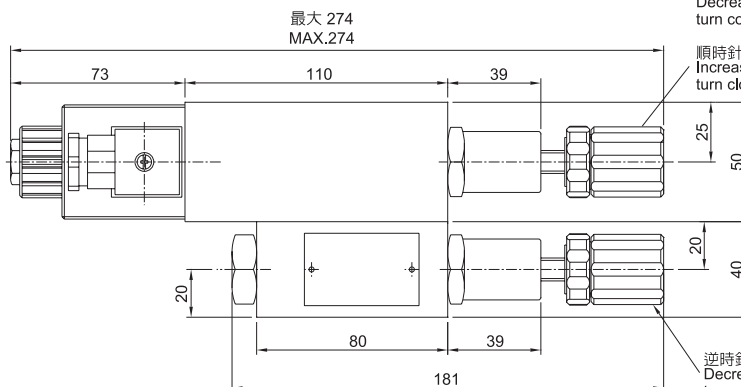
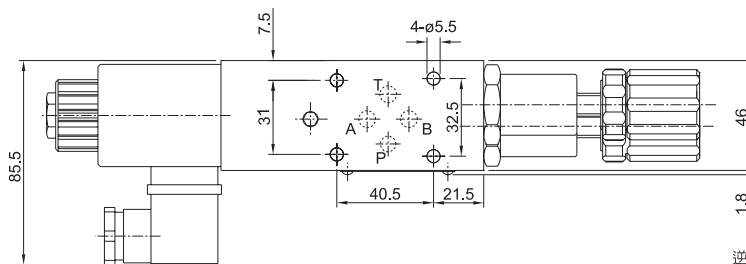

逆時針轉動 P 孔壓力減少  
Decreasing the Pressure of P port,  
turn counterclockwise

順時針轉動 P 孔壓力增加  
Increasing the Pressure of P port,  
turn clockwise

逆時針轉動 P 孔壓力減少  
Decreasing the Pressure of P port,  
turn counterclockwise

順時針轉動 P 孔壓力增加  
Increasing the Pressure of P port,  
turn clockwise



# 積層型順序閥 Modular Sequence Valve

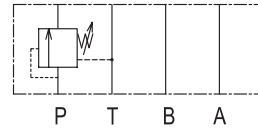

## 型號說明 / HOW TO ORDER :

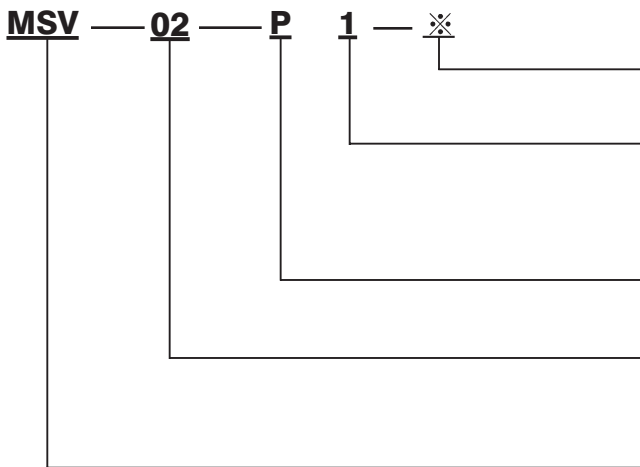

調節型式 : K : 旋鈕 ; 無 : 螺絲調整鈕  
 ADJUSTING TYPE: K: with knob none: without

壓力調整範圍 PRESSURE ADJUSTING RANGE  
 1: 8-70 kgf/cm<sup>2</sup>  
 2: 8-140 kgf/cm<sup>2</sup>  
 3: 70-250 kgf/cm<sup>2</sup>

控制孔 CONTROL PORT  
 P: P孔 P port

通徑 PORT SIZE  
 02 : 1/4"  
 03 : 3/8"

積層型順序閥 Modular Sequence Valve Series

## 規格說明 / SPECIFICATIONS :

型式 MODEL	最高使用壓力 MAX. PRESSURE kgf/cm <sup>2</sup>	壓力調節範圍 PRESSURE ADJ RANGE kgf/cm <sup>2</sup>	最大流量 MAX. FLOW LPM	重量 WEIGHT (kg)
MSV-02-P	250	1 : 8-70 2 : 35-140 3 : 70-250	50	1.3
MSV-03-P	250	1 : 8-70 2 : 35-140 3 : 70-250	100	4.5



# 積層型順序閥

# Modular Sequence Valve

## 安裝尺寸 / INSTALLATION DIMENSIONS :

單位 UNIT : mm

### ■ MSV-02-P

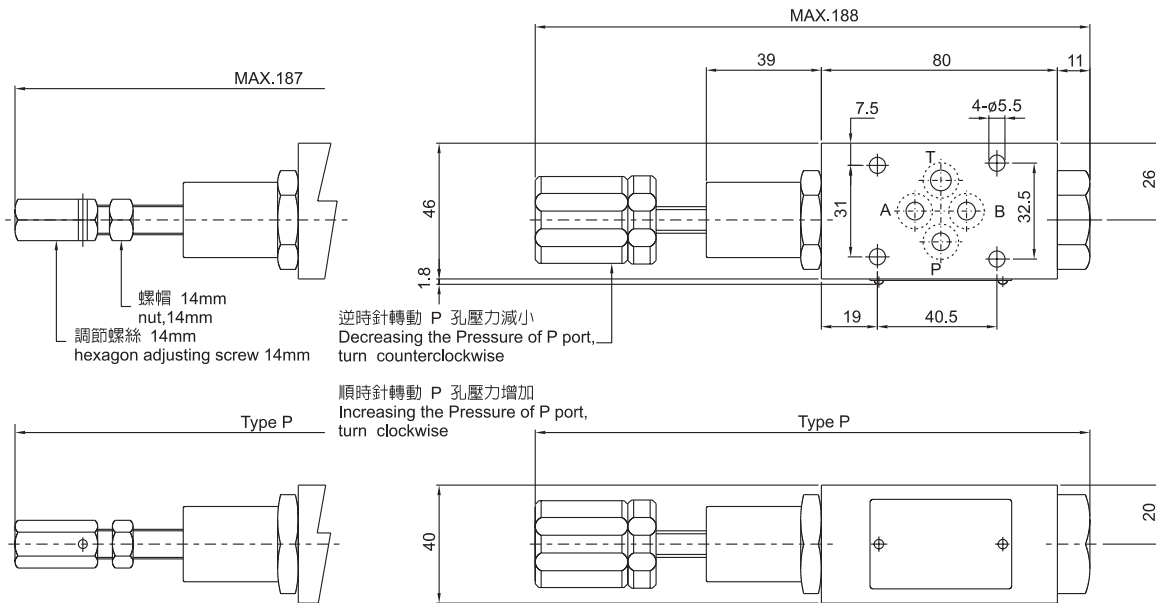

### ■ MSV-03-P

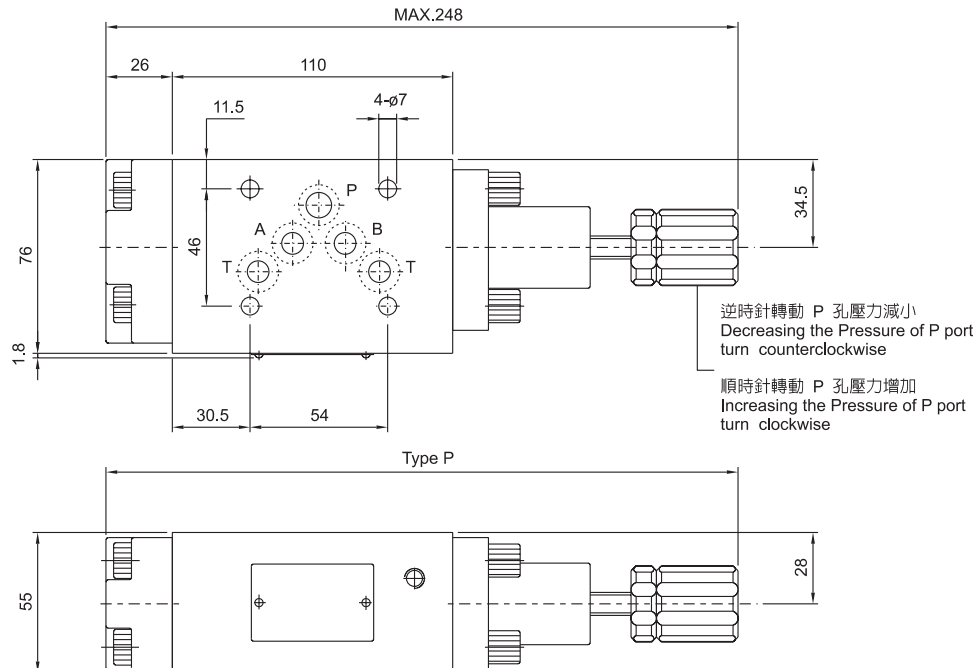



# 積層型抗衡閥

# Modular Counter Balance Valve

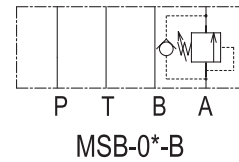
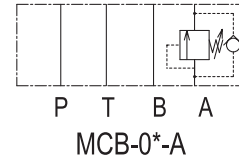
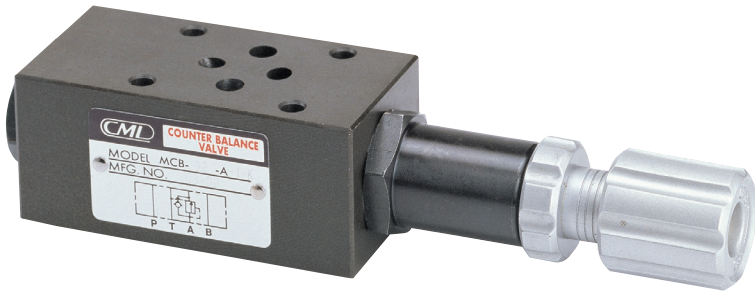

## 型號說明 / HOW TO ORDER :

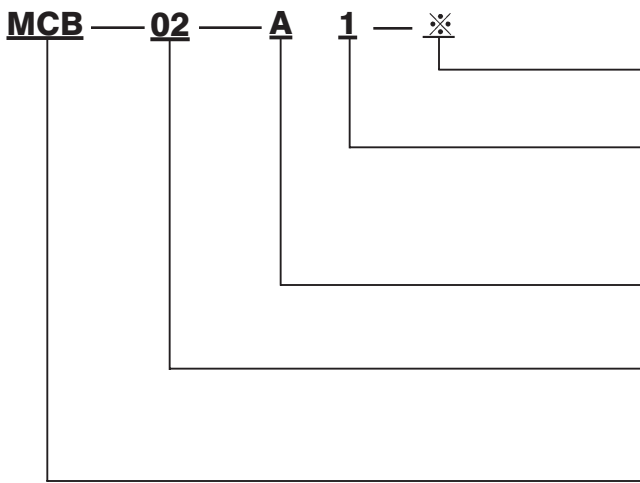

調節型式 : K : 旋鈕 ; 無 : 螺絲調整鈕  
 ADJUSTING TYPE: K: with knob none: without

壓力調整範圍 PRESSURE ADJUSTING RANGE  
 1: 8-70 kgf/cm<sup>2</sup>  
 2: 8-140 kgf/cm<sup>2</sup>  
 3: 70-250 kgf/cm<sup>2</sup>

控制孔 CONTROL PORT  
 A: A孔 A port B: B孔 B port

通徑 PORT SIZE  
 02 : 1/4"  
 03 : 3/8"

積層型抗衡閥 Modular Counter Balance Valve Series

## 規格說明 / SPECIFICATIONS :

型式 MODEL	最高使用壓力 MAX. PRESSURE kgf/cm <sup>2</sup>	壓力調節範圍 PRESSURE ADJ RANGE kgf/cm <sup>2</sup>	最大流量 MAX. FLOW LPM	重量 WEIGHT (kg)
MCB-02-A/B	250	1 : 8-70 2 : 35-140 3 : 70-250	50	1.6
MCB-03-A/B	250	1 : 8-70 2 : 35-140 3 : 70-250	100	4.5



# 積層型抗衡閥

# Modular Counter Balance Valve

## 安裝尺寸 / INSTALLATION DIMENSIONS :

單位 UNIT : mm

### ■ MCB-02-A. B

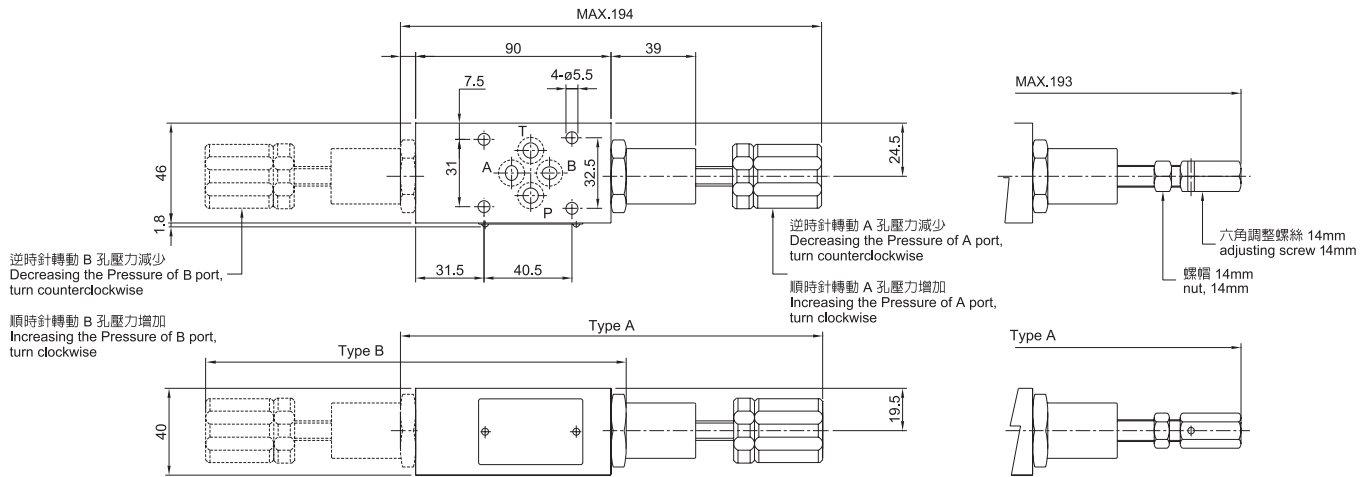

### ■ MCB-03-A. B

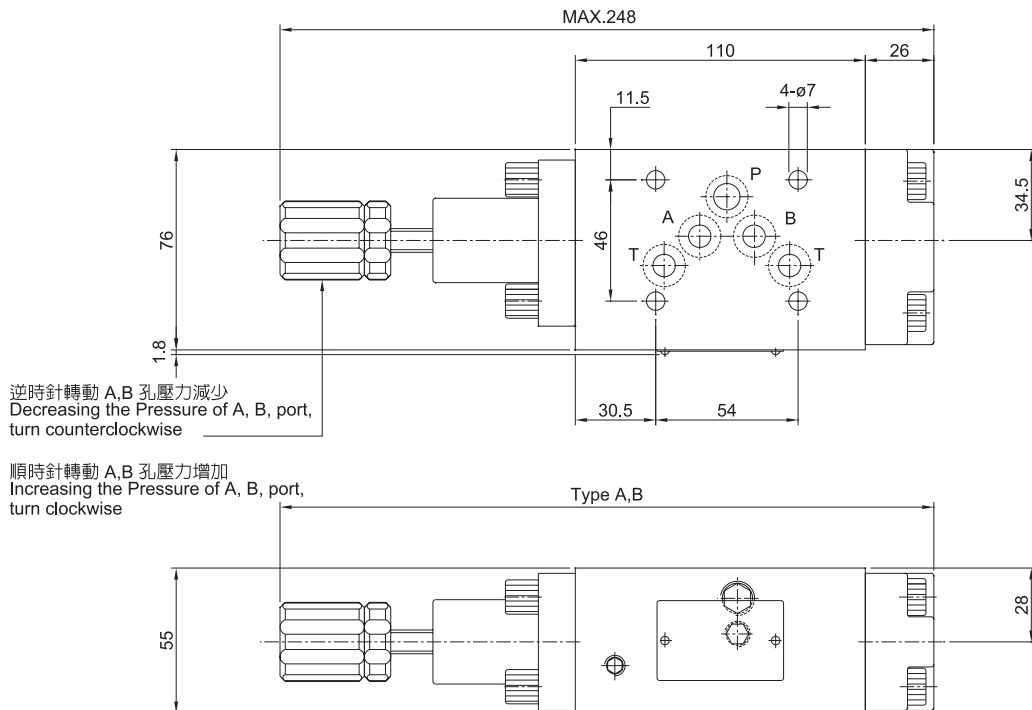



# 積層型平衡閥 Modular Balance Valve

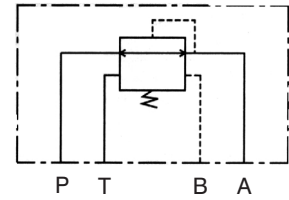

## 型號說明 / HOW TO ORDER :

**MRB — 02 — G A — 1**

- 壓力調整範圍 **PRESSURE ADJUSTING RANGE**  
 1: 8-70 kgf/cm<sup>2</sup>  
 2: 8-140 kgf/cm<sup>2</sup>  
 3: 70-250 kgf/cm<sup>2</sup>
- 控制孔 **CONTROL PORT**  
 A: A孔 **A port**
- 板式安裝 **Subplate Mounting**
- 通徑 **PORT SIZE**  
 02 : 1/4"  
 03 : 3/8"
- 積層型平衡閥 **Modular Balance Valve Series**

## 規格說明 / SPECIFICATIONS :

型式 MODEL	最高使用壓力 MAX. PRESSURE kgf/cm <sup>2</sup>	壓力調節範圍 PRESSURE ADJ RANGE kgf/cm <sup>2</sup>	最大流量 MAX. FLOW LPM	重量 WEIGHT (kg)
MRB-02G-A	250	1 : 8-70    2 : 35-140 3 : 70-250	30	1.1
MRB-03G-A	250	1 : 8-70    2 : 35-140 3 : 70-250	50	4.2





# 積層型流量控制閥

## Modular Throttle Valve

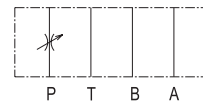

MT-02-P

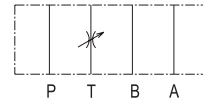

MT-02-T



MT-02-A



MT-02-B

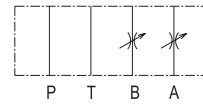

MT-02-W

### 型號說明 / HOW TO ORDER :

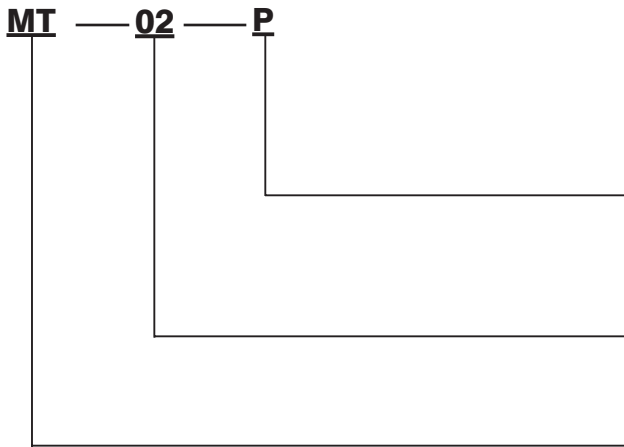

控制孔 CONTROL PORT  
 P: P孔 P port    T: T孔 T port  
 A: A孔 A port    W: A和B孔 A and B port  
 B: B孔 B port

通徑 PORT SIZE  
 02 : 1/4"  
 03 : 3/8"

積層型流量控制閥 Modular Throttle Valve Series

### 規格說明 / SPECIFICATIONS :

型式 MODEL	最高使用壓力 MAX. PRESSURE kgf/cm <sup>2</sup>	最大流量 MAX. FLOW LPM	重量 WEIGHT (kg)
MT-02-P,T	250	50	1.3
MT-02-W/A,B			1.5 / 1.4
MT-03-P,T	250	100	2.6
MT-03-W/A,B			3.1 / 2.9



# 積層型流量控制閥 Modular Throttle Valve

## 安裝尺寸 / INSTALLATION DIMENSIONS :

單位 UNIT : mm

### ■ MT-02-P. T

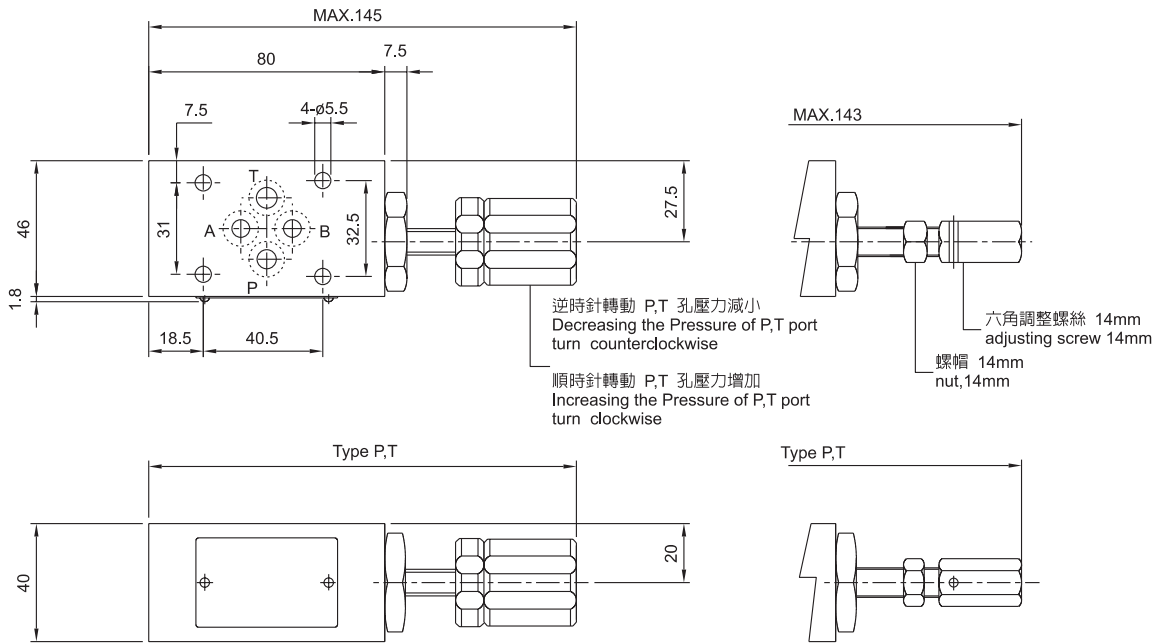

### ■ MT-02-W. A. B

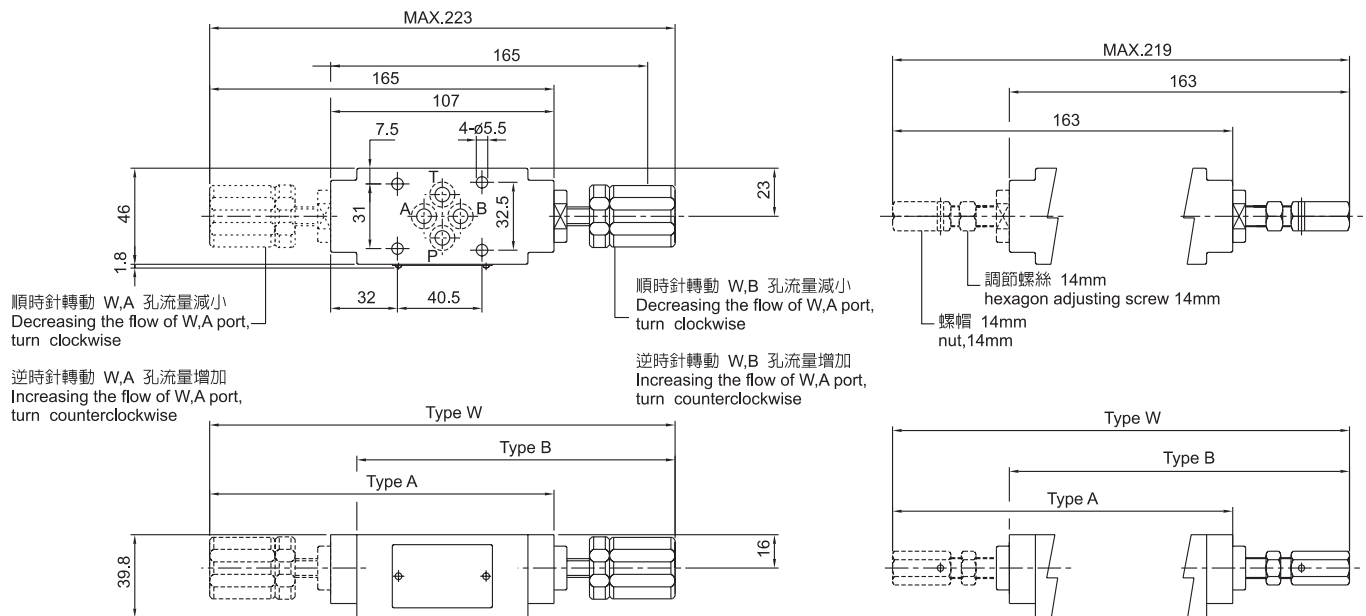



# 積層型流量控制閥 Modular Throttle Valve

## 安裝尺寸 / INSTALLATION DIMENSIONS :

單位 UNIT : mm

### ■ MT-03-P. T

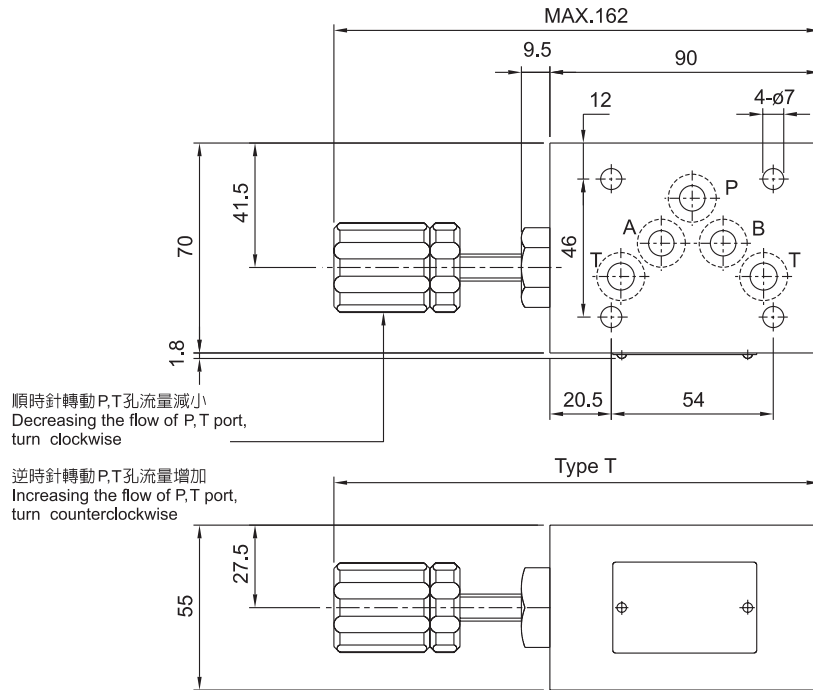

### ■ MT-03-W. A. B

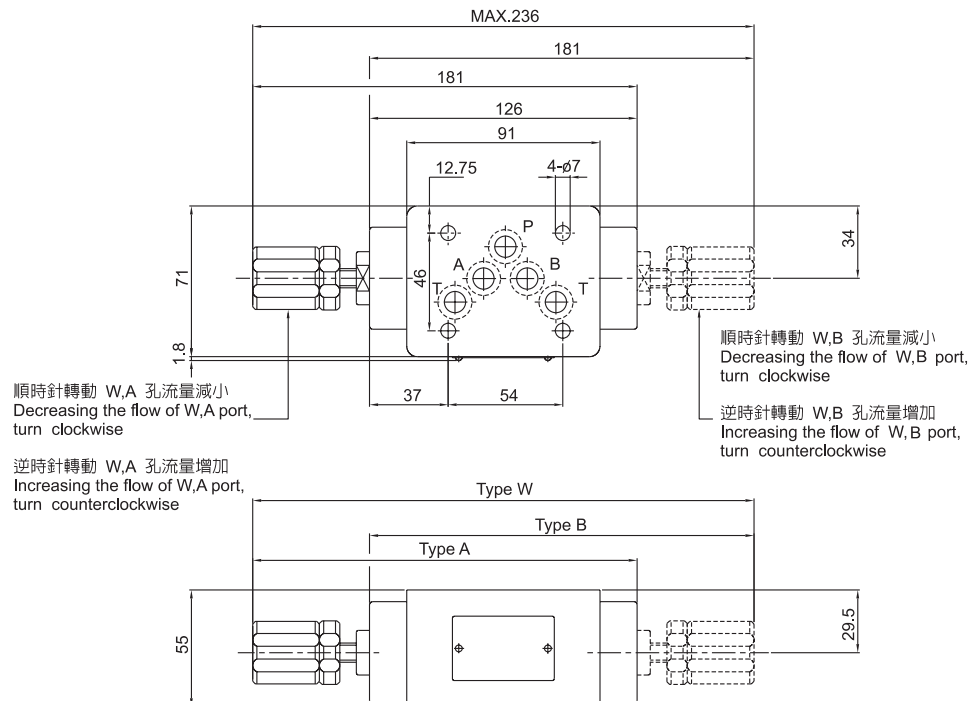



# 積層型附止逆流量控制閥

## Modular Throttle and Check Valve

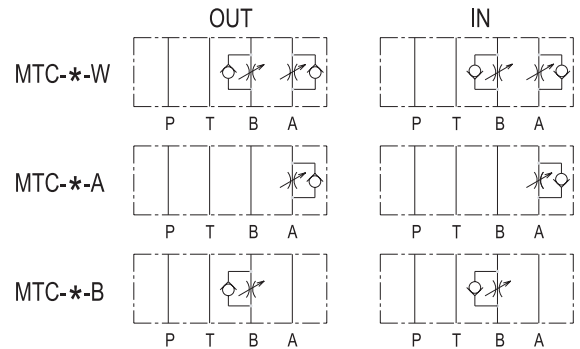

### 型號說明 / HOW TO ORDER :

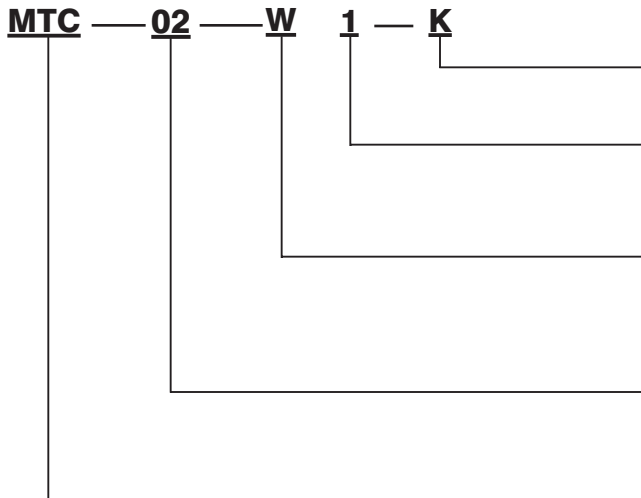

調節型式 : K : 旋鈕 ; 無 : 螺絲調整鈕  
 ADJUSTING TYPE: K: with knob none: without

制流方向 DIRECTION OF FLOW  
 1: 入口制流 1: Meter in  
 無 : 出口制流 None: Meter out

控制孔 CONTROL PORT  
 W: A和B孔 W: A and B port  
 A: A 孔 A: A port  
 B: B 孔 B: B port

通徑 PORT SIZE  
 02 : 1/4" 06 : 3/4"  
 03 : 3/8"

積層型附止逆流量控制閥 Modular Throttle Check Valve Series

### 規格說明 / SPECIFICATIONS :

型式 MODEL	最高使用壓力 MAX. PRESSURE kgf/cm <sup>2</sup>	最大流量 MAX. FLOW LPM	重量 WEIGHT (kg)
MTC-02-A,B	250	50	1.3
MTC-02-W			1.5
MTC-03-A,B	250	100	2.8
MTC-03-W			3.0
MTC-06-A,B	250	180	13.0
MTC-06-W			13.5



# 積層型附止逆流量控制閥

# Modular Throttle and Check Valve

## 安裝尺寸 / INSTALLATION DIMENSIONS :

單位 UNIT : mm

### ■ MTC-02

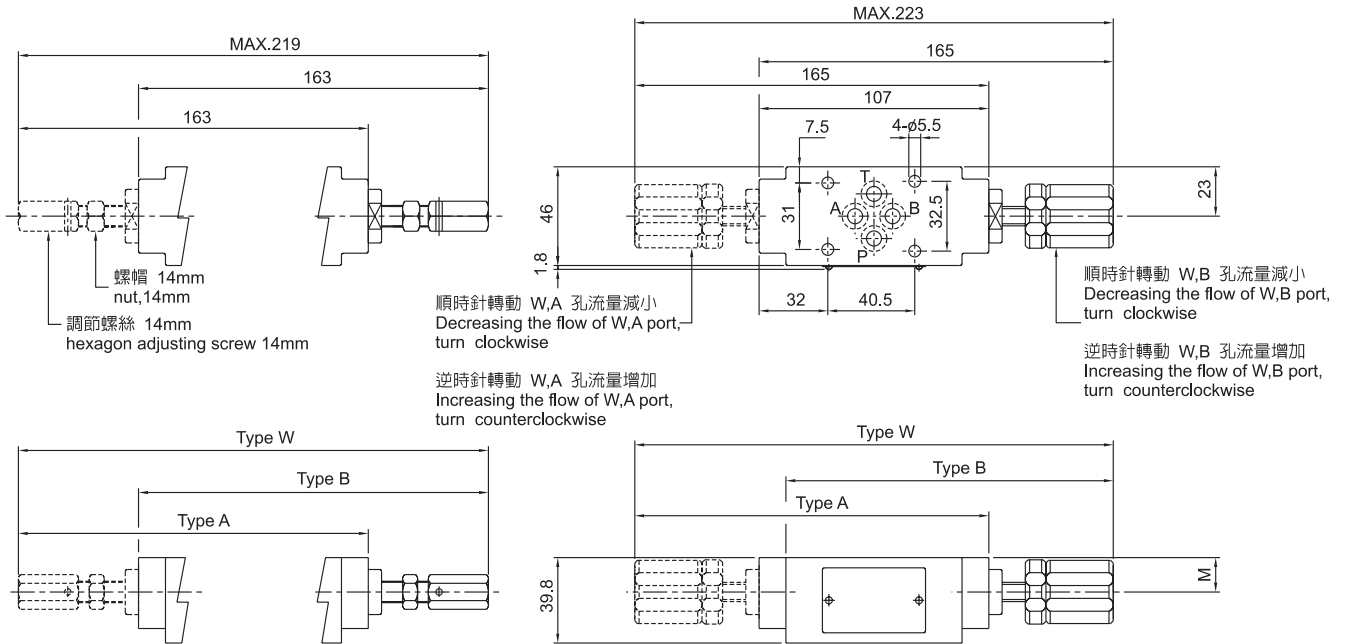

型式 MODEL	M
入口制流 Meter in	23.8
出口制流 Meter out	16

### ■ MTC-03-W. A. B

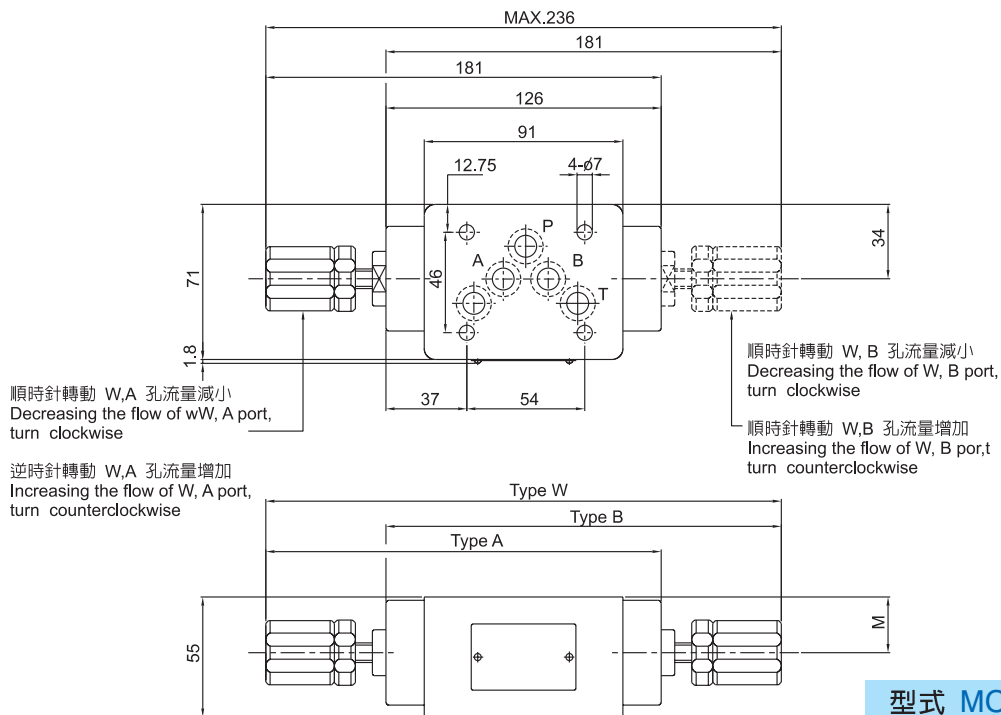

型式 MODEL	M
入口制流 Meter in	29.8
出口制流 Meter out	25.5



# 積層型附止逆流量控制閥

## Modular Throttle and Check Valve

### 安裝尺寸 / INSTALLATION DIMENSIONS :

單位 UNIT : mm

#### ■ MTC-06-W. A. B

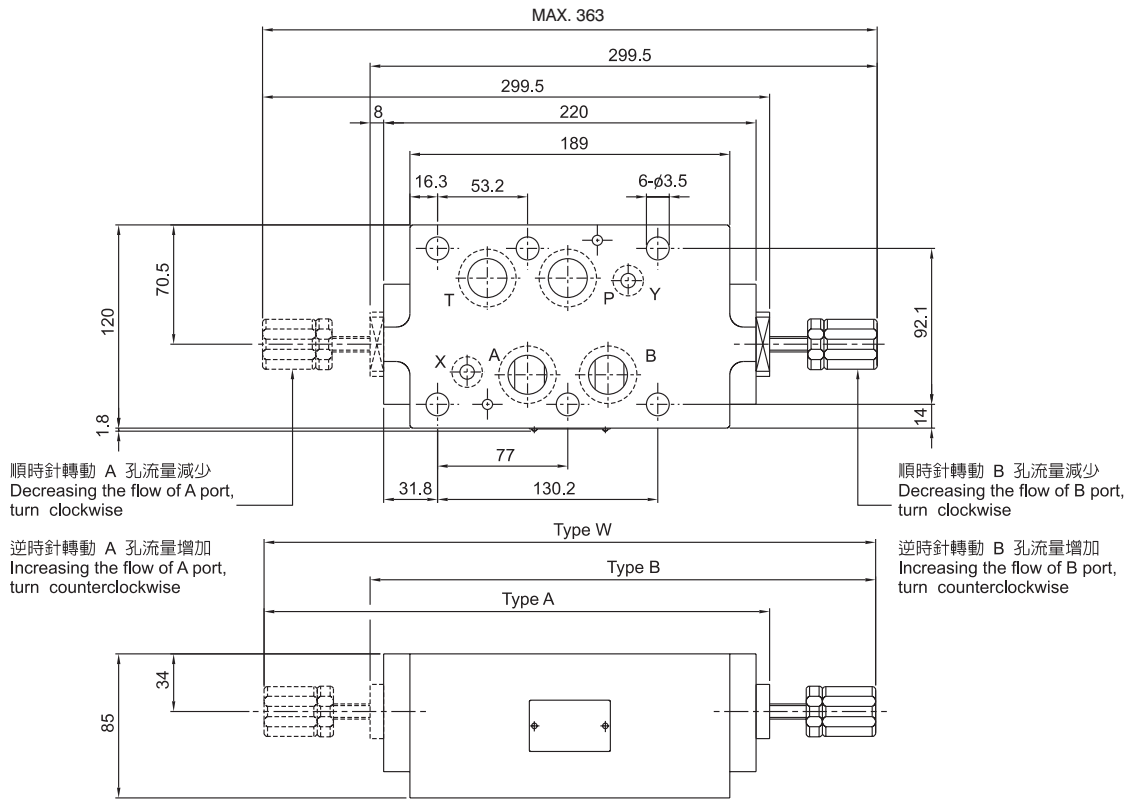

型式 MODEL	M
入口制流 Meter in	51
出口制流 Meter out	34



# 積層型附止逆流節流閥

## Modular Counter Restrictors Valve

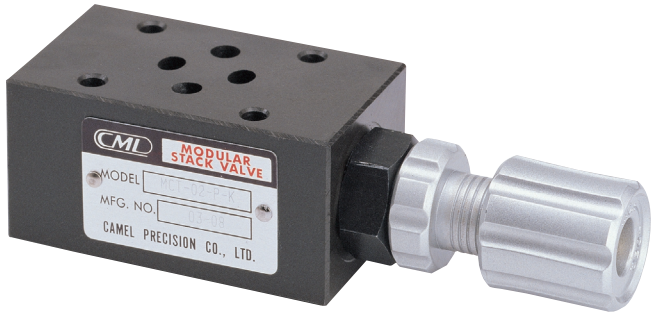

MCT-0\*-P

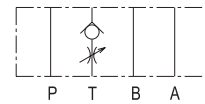

MCT-0\*-T

### 型號說明 / HOW TO ORDER :

**MCT — 02 — P**

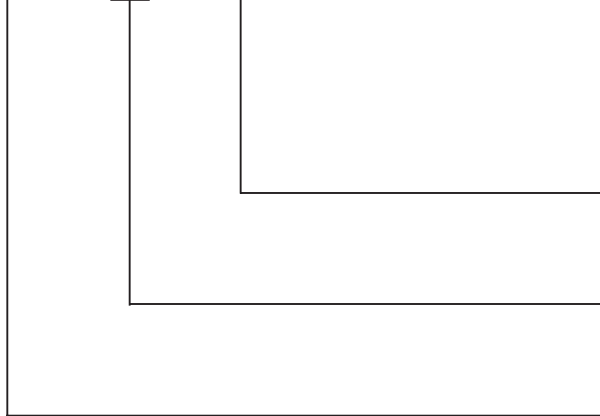

控制孔 CONTROL PORT

P: P 孔 P port

T: T 孔 T port

通徑 PORT SIZE

02 : 1/4" 06 : 3/4"

03 : 3/8"

積層型附止逆流節流閥  
Modular Counter Restrictors Valve Series

### 規格說明 / SPECIFICATIONS :

型式 MODEL	最高使用壓力 MAX. PRESSURE kgf/cm <sup>2</sup>	最大流量 MAX. FLOW LPM	重量 WEIGHT (kg)
MCT-02-P/T	250	50	1.3
MCT-03-P/T	250	100	2.7
MCT-06-P/T	250	100	13.5



# 積層型附止逆流節流閥

# Modular Counter Restrictors Valve

## 安裝尺寸 / INSTALLATION DIMENSIONS :

單位 UNIT : mm

### ■ MCT-02-P.T

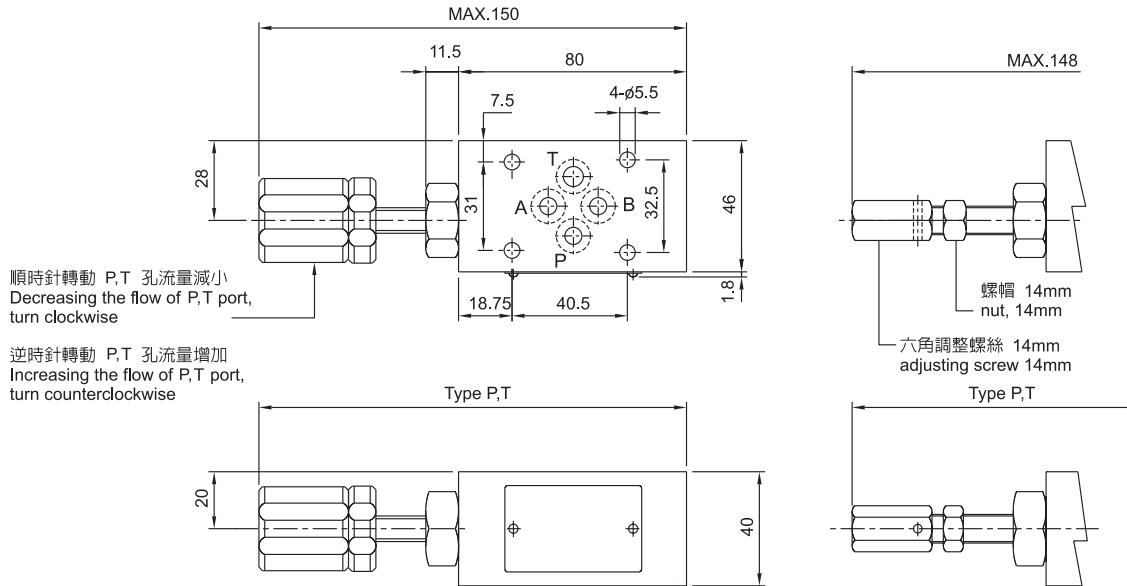

### ■ MCT-03-P.T

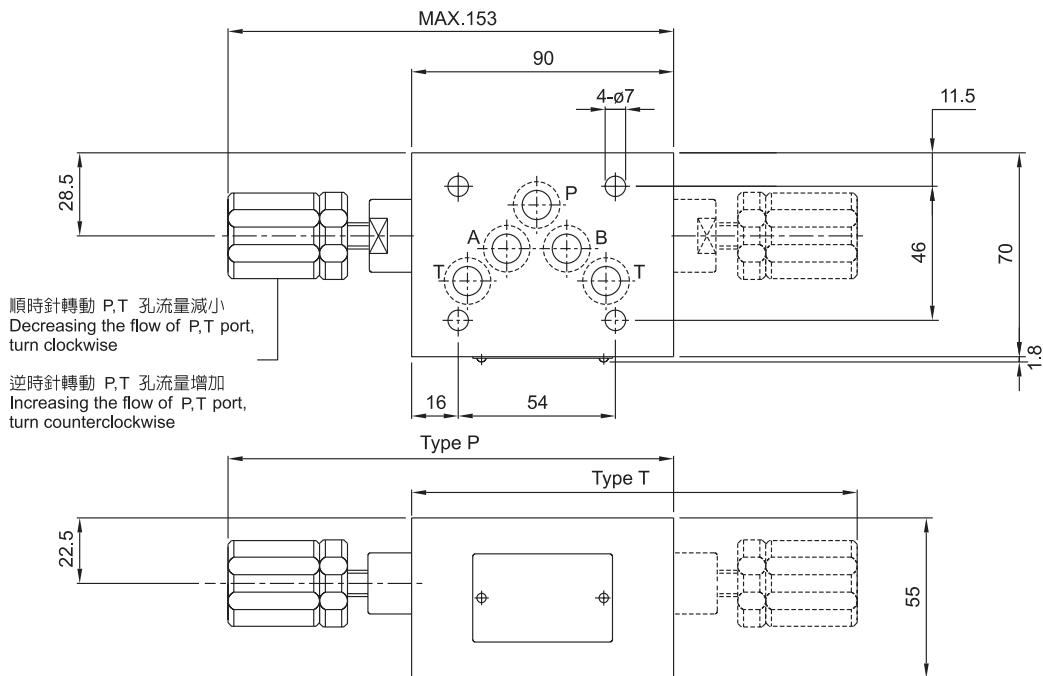



# 積層型附止逆流節流閥

## Modular Counter Restrictors Valve

### 安裝尺寸 / INSTALLATION DIMENSIONS :

單位 UNIT : mm

#### ■ MCT-06-P. T

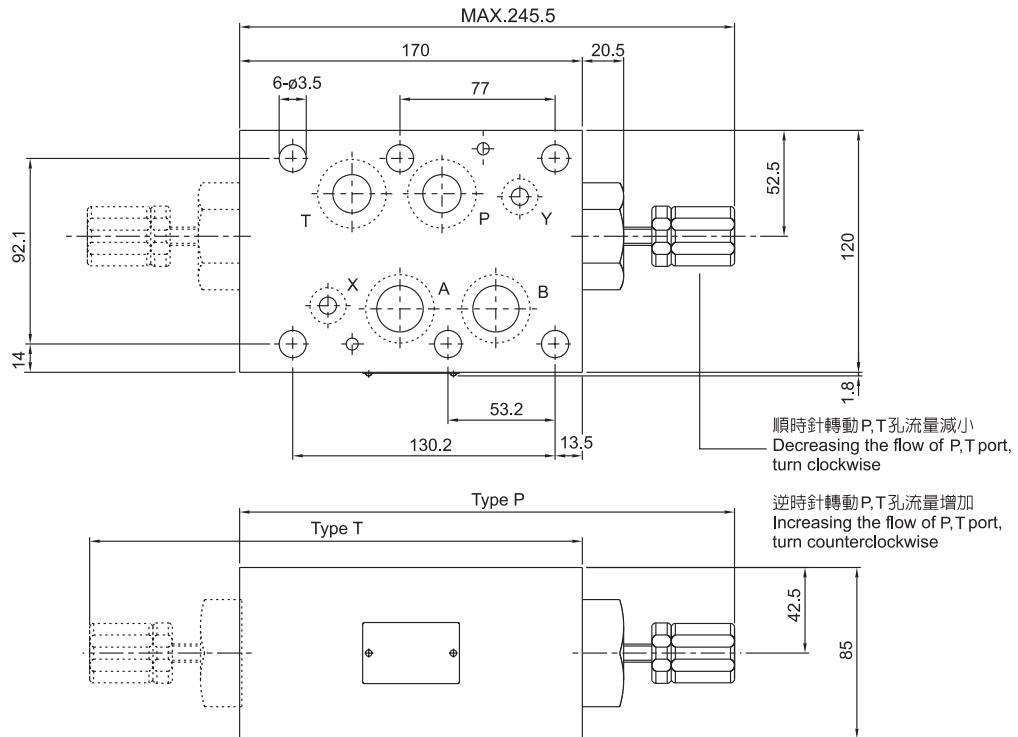



# 積層型電磁流量控制閥

## Solenoid Operated Throttle Valve

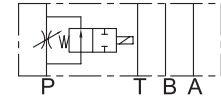

MST-02-P

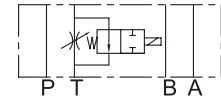

MST-02-T

### 型號說明 / HOW TO ORDER :

**MST** — **02** — **P** — **A110N**

線圈電壓  
COIL VOLTAGE  
A110N/A220N  
DC12N/DC24N

控制孔  
CONTROL PORT  
**T**: T PORT  
**P**: P PORT

通徑  
VALVET SIZE  
**02**: 1/4"

系列編號  
GROUP

### 規格說明 / SPECIFICATIONS :

型式 MODEL	壓力 RATED PRESSURE	流量 RATED FLOW
MST -02-*	70 kgf/cm <sup>2</sup>	20 l/min





# 積層型止回閥

## Modular Check Valve

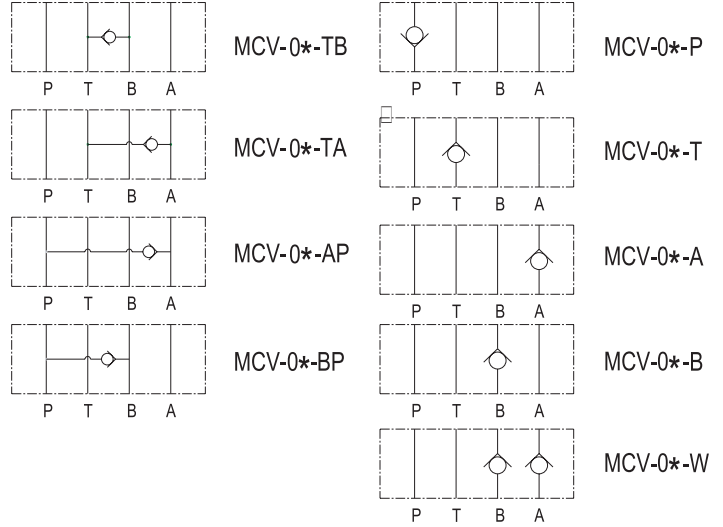

### 型號說明 / HOW TO ORDER :

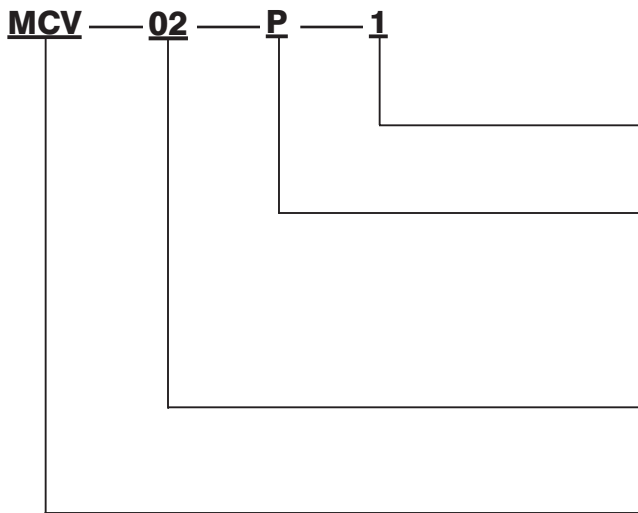

開啓壓力 **CRACKING PRESSURE**  
 1 : 0.5 kgf/cm<sup>2</sup>    2 : 4.5 kgf/cm<sup>2</sup>

控制孔 **CONTROL PORT**  
 P: P孔 **P port**    TA: A至T孔 **A to T port**  
 T: T孔 **T port**    TB: B至T孔 **B to T port**  
 A: A孔 **A port**    AP: P至A孔 **P to A port**  
 B: B孔 **B port**    BP: P至B孔 **P to B port**  
 W: A和B孔 **A and B port**

通徑 **PORT SIZE**  
 02 : 1/4"    06 : 3/4"  
 03 : 3/8"

積層型止回閥 **Modular Check Valve Series**

### 規格說明 / SPECIFICATIONS :

型式 MODEL	最高使用壓力 MAX. PRESSURE kgf/cm <sup>2</sup>	最大流量 MAX. FLOW l/min	開啓壓力 CRACKING PRESSURE kgf/cm <sup>2</sup>	重量 WEIGHT (kg)
MCV-02-P/T/A/B/TA/TB/PA/PB	250	50	1 : 0.5    2 : 4.5	1.2
MCV-02-W				1.3
MCV-03-P/T/A/B/TA/TB/PA/PB	250	100	1 : 0.5    2 : 4.5	2.5
MCV-03-W				3.5
MCV-06-P	250	180	1 : 0.5    2 : 4.5	14.0



# 積層型止回閥

# Modular Check Valve

## 安裝尺寸 / INSTALLATION DIMENSIONS :

單位 UNIT : mm

### ■ MCV-02-A. B. P. T. AP. BP. TA. TB

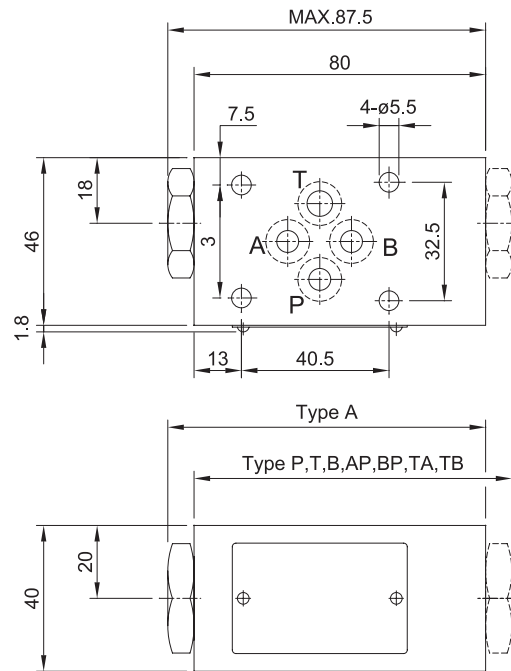

### ■ MCV-02-W

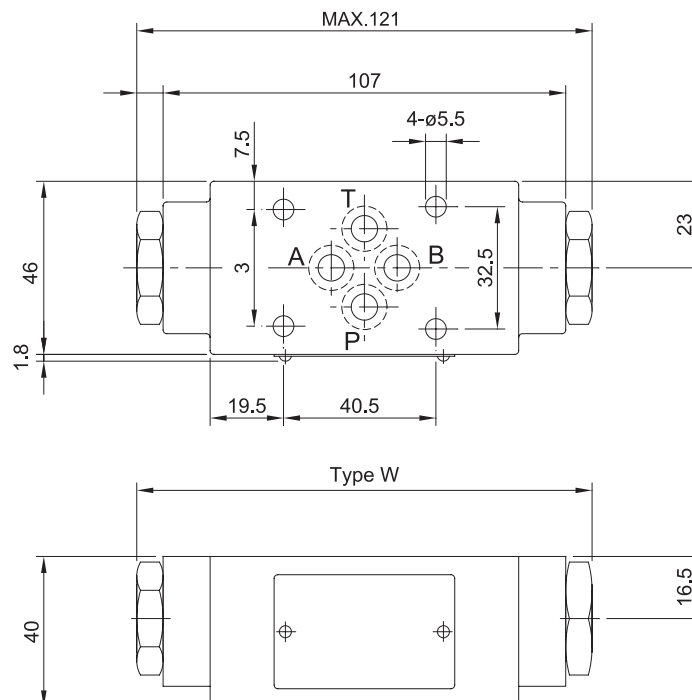



# 積層型止回閥

# Modular Check Valve

## 安裝尺寸 / INSTALLATION DIMENSIONS :

單位 UNIT : mm

### ■ MCV-03

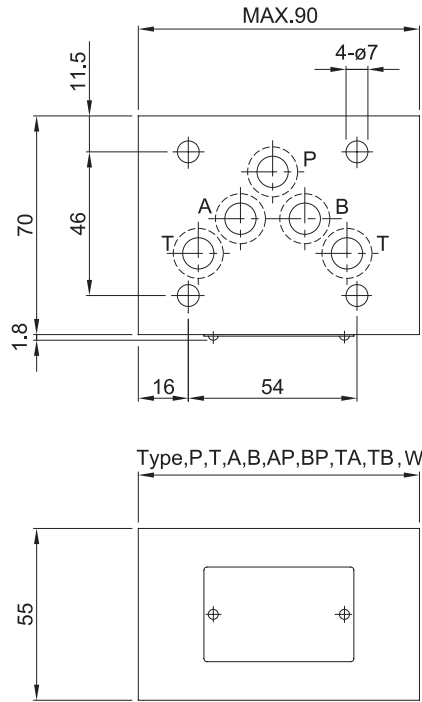

### ■ MCV-06-P

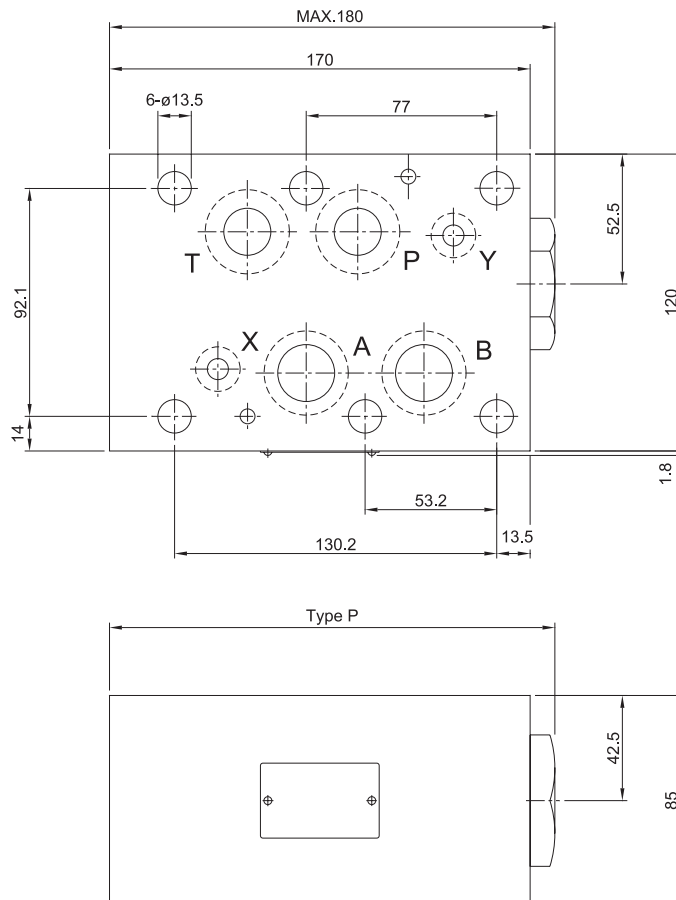



# 積層型引導止回閥

# Modular Pilot Operated Check Valve

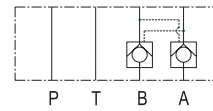

MPC-0\*-W

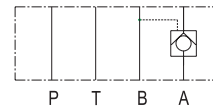

MPC-0\*-A

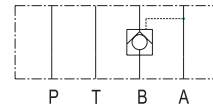

MPC-0\*-B

## 型號說明 / HOW TO ORDER :

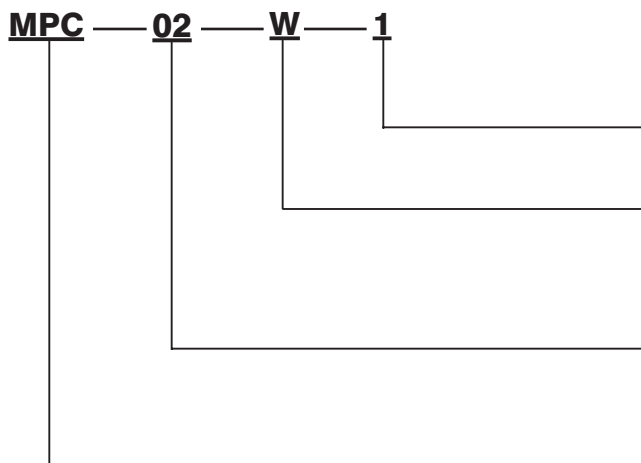

開啓壓力 **CRACKING PRESSURE**  
 1 : 0.5 kgf/cm<sup>2</sup>    2 : 5 kgf/cm<sup>2</sup>

控制孔 **CONTROL PORT**  
 W: A和B孔, A and B port  
 A: A孔, A port  
 B: B孔, B port

通徑 **PORT SIZE**  
 02 : 1/4"    06 : 3/4"  
 03 : 3/8"

積層型引導止回閥 **Modular Pilot Operated Check Valve Series**

## 規格說明 / SPECIFICATIONS :

型式 MODEL	最高使用壓力 MAX. PRESSURE kgf/cm <sup>2</sup>	最大流量 MAX. FLOW l/min	開啓壓力 CRACKING PRESSURE kgf/cm <sup>2</sup>	重量 WEIGHT (kg)
MPC-02-A/B/W	250	150	1 : 0.5    2 : 5.0	1.4
MPC-03-A/B/W	250	100	1 : 0.5    2 : 5.0	3.0
MPC-06-A/B/W	250	180	1 : 0.5    2 : 5.0	13.5



# 積層型引導止回閥

# Modular Pilot Operated Check Valve

## 安裝尺寸 / INSTALLATION DIMENSIONS :

單位 UNIT : mm

### ■ MPC-02-W. A. B

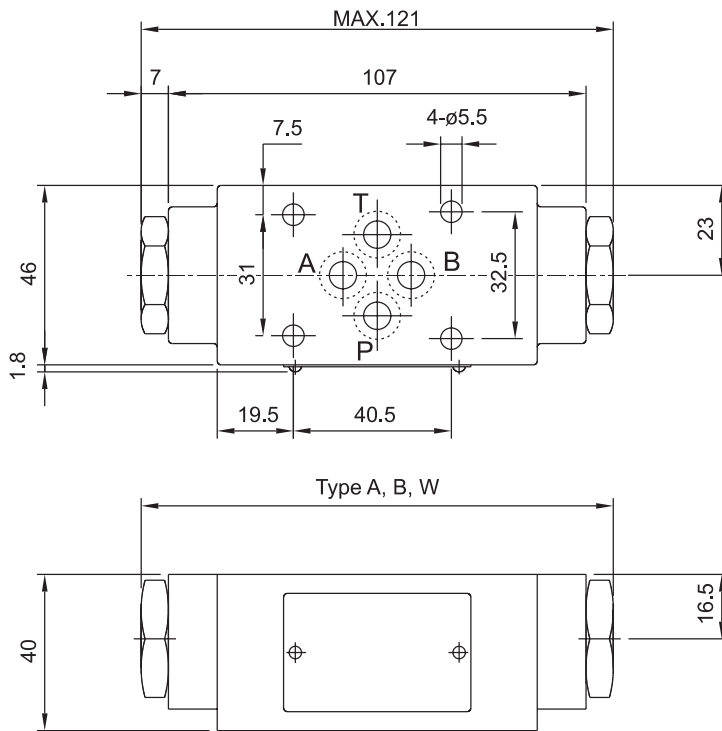

### ■ MPC-03-W. A. B

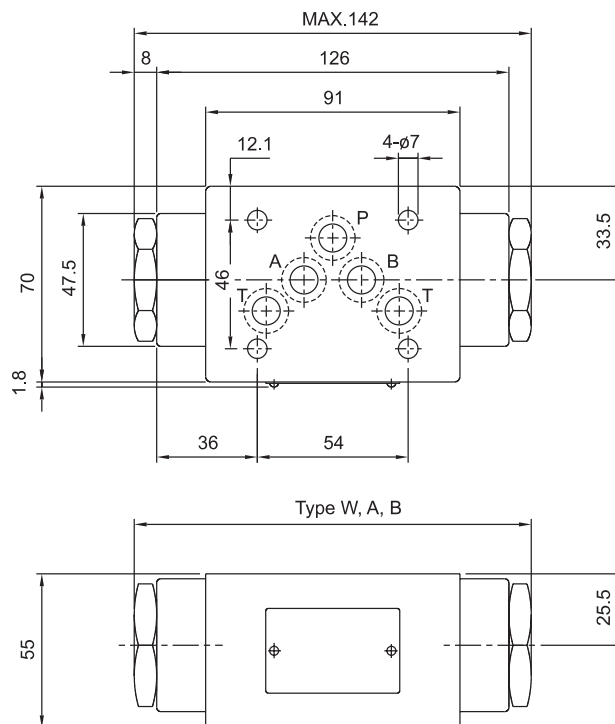



# 積層型引導止回閥

## Modular Pilot Operated Check Valve

### 安裝尺寸 / INSTALLATION DIMENSIONS :

單位 UNIT : mm

#### ■ MPC-06

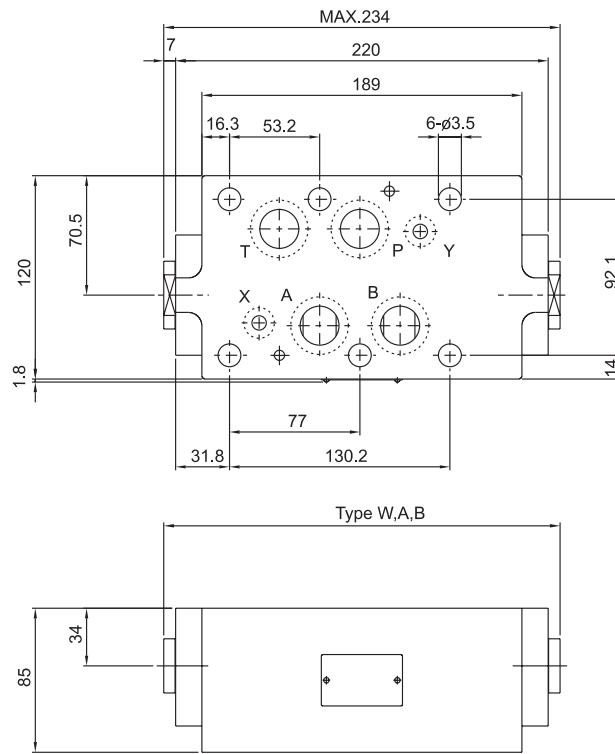



# 油路板 MA-02 系列 Manifold Block MA-02

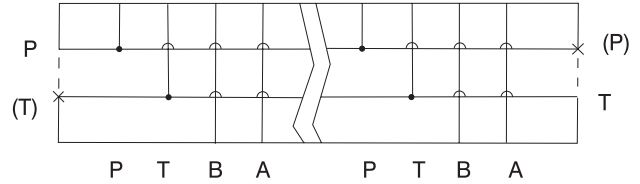

## 型號說明 / HOW TO ORDER :

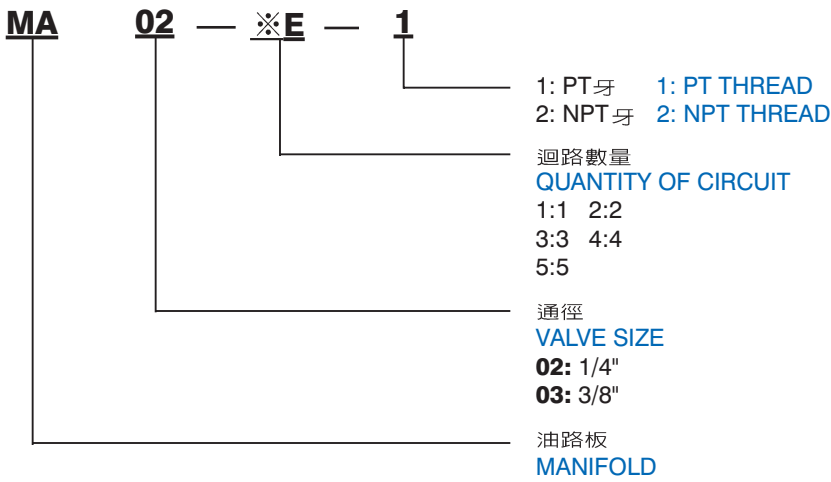

型式 MODEL	MA-0-1E-1	MA-02-1E-2
D	PT 3/8"	NPT3/8"
E	M5x0.8P	#10-24UNC

## 安裝尺寸 / INSTALLATION DIMENSIONS :

### ■ MA-02-1E

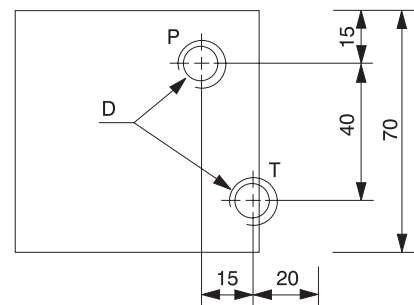
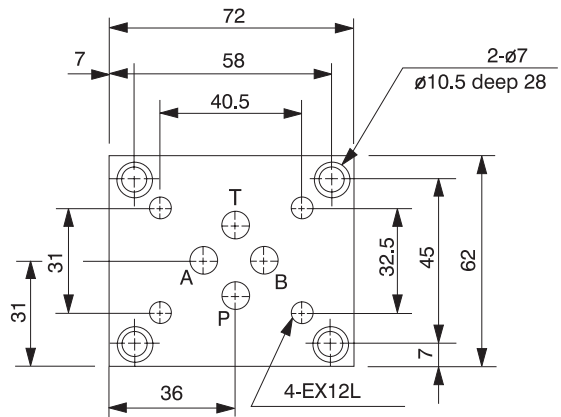
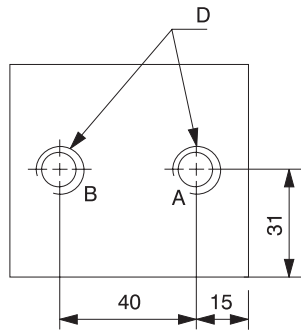



# 油路板 MA-02 系列

## Manifold Block MA-02

### MA-02-1E

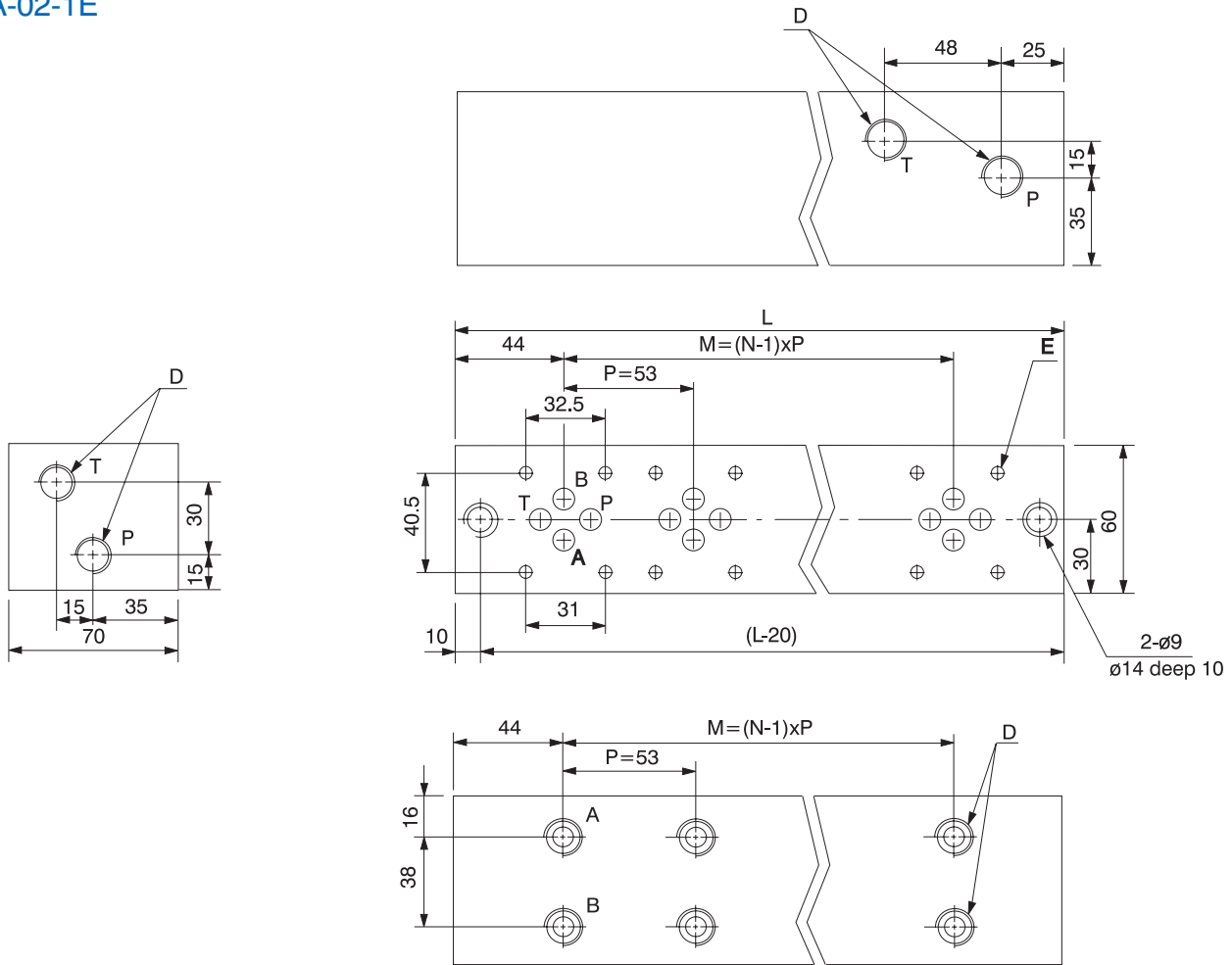

型式	MODEL	D	E	N	M	L	重量 WEIGHT(kg)
MA-02-2E	1	PT 3/8"	M5x0.8P	2	53	141	4.6
	2	NPT 3/8"	#10-24UNC				
MA-02-3E	1	PT 3/8"	M5x0.8P	3	106	194	6.3
	2	NPT 3/8"	#10-24UNC				
MA-02-4E	1	PT 3/8"	M5x0.8P	4	159	247	8.1
	2	NPT 3/8"	#10-24UNC				
MA-02-5E	1	PT 3/8"	M5x0.8P	5	212	300	10.0
	2	NPT 3/8"	#10-24UNC				
MA-02-6E	1	PT 3/8"	M5x0.8P	6	265	353	11.8
	2	NPT 3/8"	#10-24UNC				
MA-02-7E	1	PT 3/8"	M5x0.8P	7	318	406	13.6
	2	NPT 3/8"	#10-24UNC				



# 油路板 MA-03 系列

## Manifold Block MA-03

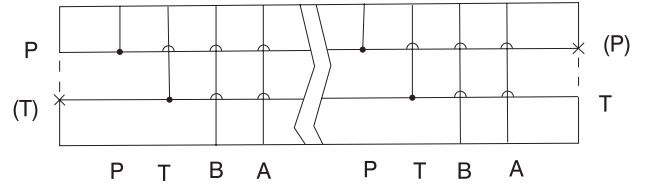
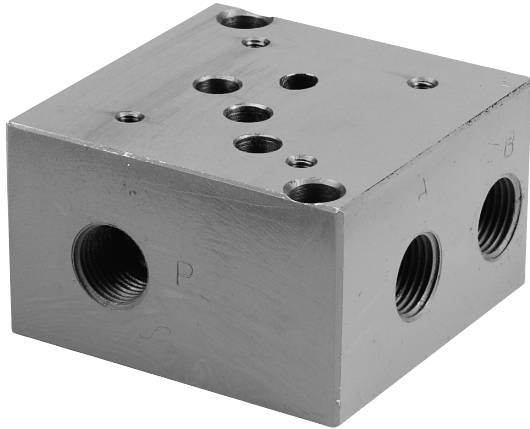

### MA-03-1E

型式 MODEL	MA-03-1E-1	MA-03-1E-2
C	PT 3/4"	NPT3/4"
D	PT 1/2"	NPT1/2"
E	M6x1P	#10-24UNC

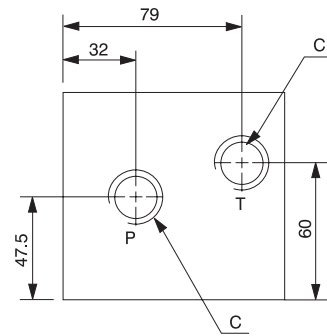
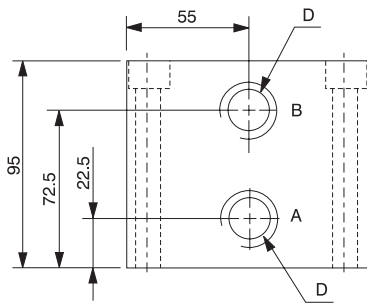
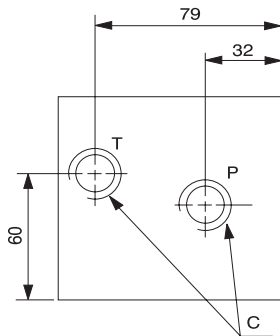
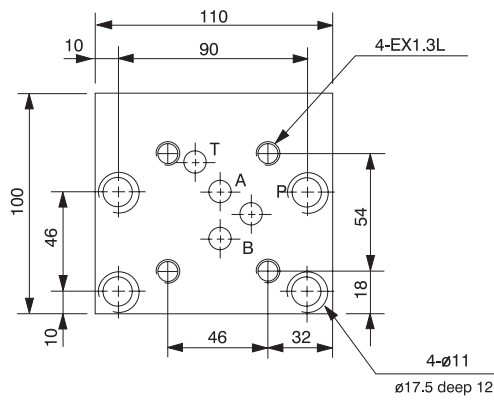



# 油路板 MA-03系列

## Manifold Block MA-03

### MA-03-E

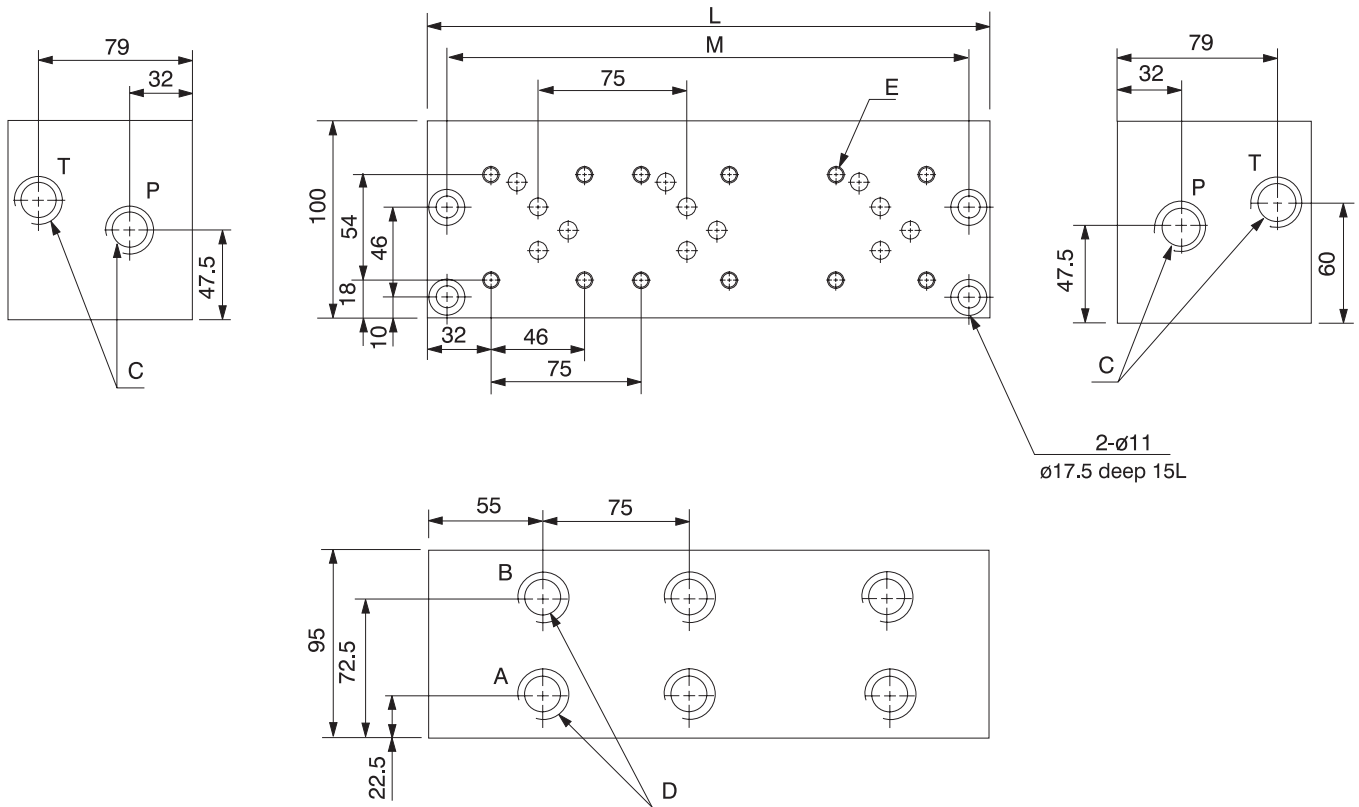

型式	MODEL	D	E	N	M	L	重量 WEIGHT(kg)
MA-03-2E	1	PT 1/2"	M6x1P	2	165	185	13.8
	2	NPT 1/2"	1/4-20UNC				
MA-03-3E	1	PT 1/2"	M6x1P	3	240	260	19.5
	2	NPT 1/2"	1/4-20UNC				
MA-03-4E	1	PT 1/2"	M6x1P	4	315	335	25.0
	2	NPT 1/2"	1/4-20UNC				
MA-03-5E	1	PT 1/2"	M6x1P	5	390	410	31.0
	2	NPT 1/2"	1/4-20UNC				

